

R&S®SGS100A SGMA RF Source Service Manual



1173.9111.02 – 03

This Service Manual provides servicing and maintenance procedures for the R&S® SGS100A

© 2012 Rohde & Schwarz GmbH & Co. KG

Muehldorfstr. 15, 81671 Munich, Germany

Phone: +49 89 41 29 – 0

Fax: +49 89 41 29 12 164

E-mail: info@rohde-schwarz.com

Internet: <http://www.rohde-schwarz.com>

Printed in Germany – Subject to change – Data without tolerance limits is not binding.

R&S® is a registered trademark of Rohde & Schwarz GmbH & Co. KG.

Trade names are trademarks of the owners.

The following abbreviations are used throughout this manual:

R&S®SGS100A is abbreviated as R&S SGS100A.

Basic Safety Instructions

Always read through and comply with the following safety instructions!



All plants and locations of the Rohde & Schwarz group of companies make every effort to keep the safety standards of our products up to date and to offer our customers the highest possible degree of safety. Our products and the auxiliary equipment they require are designed, built and tested in accordance with the safety standards that apply in each case. Compliance with these standards is continuously monitored by our quality assurance system. The product described here has been designed, built and tested in accordance with the attached EC Certificate of Conformity and has left the manufacturer's plant in a condition fully complying with safety standards. To maintain this condition and to ensure safe operation, you must observe all instructions and warnings provided in this manual. If you have any questions regarding these safety instructions, the Rohde & Schwarz group of companies will be happy to answer them.

Furthermore, it is your responsibility to use the product in an appropriate manner. This product is designed for use solely in industrial and laboratory environments or, if expressly permitted, also in the field and must not be used in any way that may cause personal injury or property damage. You are responsible if the product is used for any purpose other than its designated purpose or in disregard of the manufacturer's instructions. The manufacturer shall assume no responsibility for such use of the product.











The product is used for its designated purpose if it is used in accordance with its product documentation and within its performance limits (see data sheet, documentation, the following safety instructions). Using the product requires technical skills and, in some cases, a basic knowledge of English. It is therefore essential that only skilled and specialized staff or thoroughly trained personnel with the required skills be allowed to use the product. If personal safety gear is required for using Rohde & Schwarz products, this will be indicated at the appropriate place in the product documentation. Keep the basic safety instructions and the product documentation in a safe place and pass them on to the subsequent users.

Observing the safety instructions will help prevent personal injury or damage of any kind caused by dangerous situations. Therefore, carefully read through and adhere to the following safety instructions before and when using the product. It is also absolutely essential to observe the additional safety instructions on personal safety, for example, that appear in relevant parts of the product documentation. In these safety instructions, the word "product" refers to all merchandise sold and distributed by the Rohde & Schwarz group of companies, including instruments, systems and all accessories. For product-specific information, see the data sheet and the product documentation.

Symbols and safety labels

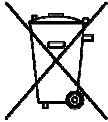
Symbol	Meaning	Symbol	Meaning
	Notice, general danger location Observe product documentation	○	ON/OFF supply voltage
	Caution when handling heavy equipment	⏻	Standby indication
	Danger of electric shock	≡	Direct current (DC)

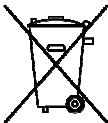
Basic Safety Instructions

Symbol	Meaning	Symbol	Meaning
	Warning! Hot surface		Alternating current (AC)
	Protective conductor terminal		Direct/alternating current (DC/AC)
	Ground		Device fully protected by double (reinforced) insulation
	Ground terminal		EU labeling for batteries and accumulators For additional information, see section "Waste disposal/Environmental protection", item 1.
	Be careful when handling electrostatic sensitive devices		EU labeling for separate collection of electrical and electronic devices For additional information, see section "Waste disposal/Environmental protection", item 2.
	Warning! Laser radiation For additional information, see section "Operation", item 7.		

Signal words and their meaning

The following signal words are used in the product documentation in order to warn the reader about risks and dangers.



Indicates an imminently hazardous situation which, if not avoided, will result in death or serious injury.



Indicates a potentially hazardous situation which, if not avoided, could result in death or serious injury.



Indicates a potentially hazardous situation which, if not avoided, could result in minor or moderate injury.



Indicates the possibility of incorrect operation which can result in damage to the product.

In the product documentation, the word ATTENTION is used synonymously.

These signal words are in accordance with the standard definition for civil applications in the European Economic Area. Definitions that deviate from the standard definition may also exist in other economic areas or military applications. It is therefore essential to make sure that the signal words described here are always used only in connection with the related product documentation and the related product. The use of signal words in connection with unrelated products or documentation can result in misinterpretation and in personal injury or material damage.

Basic Safety Instructions

Operating states and operating positions

The product may be operated only under the operating conditions and in the positions specified by the manufacturer, without the product's ventilation being obstructed. If the manufacturer's specifications are not observed, this can result in electric shock, fire and/or serious personal injury or death. Applicable local or national safety regulations and rules for the prevention of accidents must be observed in all work performed.

1. Unless otherwise specified, the following requirements apply to Rohde & Schwarz products: predefined operating position is always with the housing floor facing down, IP protection 2X, use only indoors, max. operating altitude 2000 m above sea level, max. transport altitude 4500 m above sea level. A tolerance of $\pm 10\%$ shall apply to the nominal voltage and $\pm 5\%$ to the nominal frequency, overvoltage category 2, pollution severity 2.
2. Do not place the product on surfaces, vehicles, cabinets or tables that for reasons of weight or stability are unsuitable for this purpose. Always follow the manufacturer's installation instructions when installing the product and fastening it to objects or structures (e.g. walls and shelves). An installation that is not carried out as described in the product documentation could result in personal injury or even death.
3. Do not place the product on heat-generating devices such as radiators or fan heaters. The ambient temperature must not exceed the maximum temperature specified in the product documentation or in the data sheet. Product overheating can cause electric shock, fire and/or serious personal injury or even death.

Electrical safety

If the information on electrical safety is not observed either at all or to the extent necessary, electric shock, fire and/or serious personal injury or death may occur.

1. Prior to switching on the product, always ensure that the nominal voltage setting on the product matches the nominal voltage of the AC supply network. If a different voltage is to be set, the power fuse of the product may have to be changed accordingly.
2. In the case of products of safety class I with movable power cord and connector, operation is permitted only on sockets with a protective conductor contact and protective conductor.
3. Intentionally breaking the protective conductor either in the feed line or in the product itself is not permitted. Doing so can result in the danger of an electric shock from the product. If extension cords or connector strips are implemented, they must be checked on a regular basis to ensure that they are safe to use.
4. If there is no power switch for disconnecting the product from the AC supply network, or if the power switch is not suitable for this purpose, use the plug of the connecting cable to disconnect the product from the AC supply network. In such cases, always ensure that the power plug is easily reachable and accessible at all times. For example, if the power plug is the disconnecting device, the length of the connecting cable must not exceed 3 m. Functional or electronic switches are not suitable for providing disconnection from the AC supply network. If products without power switches are integrated into racks or systems, the disconnecting device must be provided at the system level.
5. Never use the product if the power cable is damaged. Check the power cables on a regular basis to ensure that they are in proper operating condition. By taking appropriate safety measures and carefully laying the power cable, ensure that the cable cannot be damaged and that no one can be hurt by, for example, tripping over the cable or suffering an electric shock.

Basic Safety Instructions

6. The product may be operated only from TN/TT supply networks fuse-protected with max. 16 A (higher fuse only after consulting with the Rohde & Schwarz group of companies).
7. Do not insert the plug into sockets that are dusty or dirty. Insert the plug firmly and all the way into the socket provided for this purpose. Otherwise, sparks that result in fire and/or injuries may occur.
8. Do not overload any sockets, extension cords or connector strips; doing so can cause fire or electric shocks.
9. For measurements in circuits with voltages $V_{\text{rms}} > 30 \text{ V}$, suitable measures (e.g. appropriate measuring equipment, fuse protection, current limiting, electrical separation, insulation) should be taken to avoid any hazards.
10. Ensure that the connections with information technology equipment, e.g. PCs or other industrial computers, comply with the IEC60950-1/EN60950-1 or IEC61010-1/EN 61010-1 standards that apply in each case.
11. Unless expressly permitted, never remove the cover or any part of the housing while the product is in operation. Doing so will expose circuits and components and can lead to injuries, fire or damage to the product.
12. If a product is to be permanently installed, the connection between the protective conductor terminal on site and the product's protective conductor must be made first before any other connection is made. The product may be installed and connected only by a licensed electrician.
13. For permanently installed equipment without built-in fuses, circuit breakers or similar protective devices, the supply circuit must be fuse-protected in such a way that anyone who has access to the product, as well as the product itself, is adequately protected from injury or damage.
14. Use suitable overvoltage protection to ensure that no overvoltage (such as that caused by a bolt of lightning) can reach the product. Otherwise, the person operating the product will be exposed to the danger of an electric shock.
15. Any object that is not designed to be placed in the openings of the housing must not be used for this purpose. Doing so can cause short circuits inside the product and/or electric shocks, fire or injuries.
16. Unless specified otherwise, products are not liquid-proof (see also section "Operating states and operating positions", item 1). Therefore, the equipment must be protected against penetration by liquids. If the necessary precautions are not taken, the user may suffer electric shock or the product itself may be damaged, which can also lead to personal injury.
17. Never use the product under conditions in which condensation has formed or can form in or on the product, e.g. if the product has been moved from a cold to a warm environment. Penetration by water increases the risk of electric shock.
18. Prior to cleaning the product, disconnect it completely from the power supply (e.g. AC supply network or battery). Use a soft, non-linting cloth to clean the product. Never use chemical cleaning agents such as alcohol, acetone or diluents for cellulose lacquers.

Operation

1. Operating the products requires special training and intense concentration. Make sure that persons who use the products are physically, mentally and emotionally fit enough to do so; otherwise, injuries or material damage may occur. It is the responsibility of the employer/operator to select suitable personnel for operating the products.

Basic Safety Instructions

2. Before you move or transport the product, read and observe the section titled "Transport".
3. As with all industrially manufactured goods, the use of substances that induce an allergic reaction (allergens) such as nickel cannot be generally excluded. If you develop an allergic reaction (such as a skin rash, frequent sneezing, red eyes or respiratory difficulties) when using a Rohde & Schwarz product, consult a physician immediately to determine the cause and to prevent health problems or stress.
4. Before you start processing the product mechanically and/or thermally, or before you take it apart, be sure to read and pay special attention to the section titled "Waste disposal/Environmental protection", item 1.
5. Depending on the function, certain products such as RF radio equipment can produce an elevated level of electromagnetic radiation. Considering that unborn babies require increased protection, pregnant women must be protected by appropriate measures. Persons with pacemakers may also be exposed to risks from electromagnetic radiation. The employer/operator must evaluate workplaces where there is a special risk of exposure to radiation and, if necessary, take measures to avert the potential danger.
6. Should a fire occur, the product may release hazardous substances (gases, fluids, etc.) that can cause health problems. Therefore, suitable measures must be taken, e.g. protective masks and protective clothing must be worn.
7. Laser products are given warning labels that are standardized according to their laser class. Lasers can cause biological harm due to the properties of their radiation and due to their extremely concentrated electromagnetic power. If a laser product (e.g. a CD/DVD drive) is integrated into a Rohde & Schwarz product, absolutely no other settings or functions may be used as described in the product documentation. The objective is to prevent personal injury (e.g. due to laser beams).
8. EMC classes (in line with CISPR 11)
Class A: Equipment suitable for use in all environments except residential environments and environments that are directly connected to a low-voltage supply network that supplies residential buildings.
Class B: Equipment suitable for use in residential environments and environments that are directly connected to a low-voltage supply network that supplies residential buildings.

Repair and service

1. The product may be opened only by authorized, specially trained personnel. Before any work is performed on the product or before the product is opened, it must be disconnected from the AC supply network. Otherwise, personnel will be exposed to the risk of an electric shock.
2. Adjustments, replacement of parts, maintenance and repair may be performed only by electrical experts authorized by Rohde & Schwarz. Only original parts may be used for replacing parts relevant to safety (e.g. power switches, power transformers, fuses). A safety test must always be performed after parts relevant to safety have been replaced (visual inspection, protective conductor test, insulation resistance measurement, leakage current measurement, functional test). This helps ensure the continued safety of the product.

Basic Safety Instructions

Batteries and rechargeable batteries/cells

If the information regarding batteries and rechargeable batteries/cells is not observed either at all or to the extent necessary, product users may be exposed to the risk of explosions, fire and/or serious personal injury, and, in some cases, death. Batteries and rechargeable batteries with alkaline electrolytes (e.g. lithium cells) must be handled in accordance with the EN 62133 standard.

1. Cells must not be taken apart or crushed.
2. Cells or batteries must not be exposed to heat or fire. Storage in direct sunlight must be avoided. Keep cells and batteries clean and dry. Clean soiled connectors using a dry, clean cloth.
3. Cells or batteries must not be short-circuited. Cells or batteries must not be stored in a box or in a drawer where they can short-circuit each other, or where they can be short-circuited by other conductive materials. Cells and batteries must not be removed from their original packaging until they are ready to be used.
4. Cells and batteries must not be exposed to any mechanical shocks that are stronger than permitted.
5. If a cell develops a leak, the fluid must not be allowed to come into contact with the skin or eyes. If contact occurs, wash the affected area with plenty of water and seek medical aid.
6. Improperly replacing or charging cells or batteries that contain alkaline electrolytes (e.g. lithium cells) can cause explosions. Replace cells or batteries only with the matching Rohde & Schwarz type (see parts list) in order to ensure the safety of the product.
7. Cells and batteries must be recycled and kept separate from residual waste. Rechargeable batteries and normal batteries that contain lead, mercury or cadmium are hazardous waste. Observe the national regulations regarding waste disposal and recycling.

Transport

1. The product may be very heavy. Therefore, the product must be handled with care. In some cases, the user may require a suitable means of lifting or moving the product (e.g. with a lift-truck) to avoid back or other physical injuries.
2. Handles on the products are designed exclusively to enable personnel to transport the product. It is therefore not permissible to use handles to fasten the product to or on transport equipment such as cranes, fork lifts, wagons, etc. The user is responsible for securely fastening the products to or on the means of transport or lifting. Observe the safety regulations of the manufacturer of the means of transport or lifting. Noncompliance can result in personal injury or material damage.
3. If you use the product in a vehicle, it is the sole responsibility of the driver to drive the vehicle safely and properly. The manufacturer assumes no responsibility for accidents or collisions. Never use the product in a moving vehicle if doing so could distract the driver of the vehicle. Adequately secure the product in the vehicle to prevent injuries or other damage in the event of an accident.

Waste disposal/Environmental protection

1. Specially marked equipment has a battery or accumulator that must not be disposed of with unsorted municipal waste, but must be collected separately. It may only be disposed of at a suitable collection point or via a Rohde & Schwarz customer service center.

Instrucciones de seguridad elementales

2. Waste electrical and electronic equipment must not be disposed of with unsorted municipal waste, but must be collected separately.
Rohde & Schwarz GmbH & Co. KG has developed a disposal concept and takes full responsibility for take-back obligations and disposal obligations for manufacturers within the EU. Contact your Rohde & Schwarz customer service center for environmentally responsible disposal of the product.
3. If products or their components are mechanically and/or thermally processed in a manner that goes beyond their intended use, hazardous substances (heavy-metal dust such as lead, beryllium, nickel) may be released. For this reason, the product may only be disassembled by specially trained personnel. Improper disassembly may be hazardous to your health. National waste disposal regulations must be observed.
4. If handling the product releases hazardous substances or fuels that must be disposed of in a special way, e.g. coolants or engine oils that must be replenished regularly, the safety instructions of the manufacturer of the hazardous substances or fuels and the applicable regional waste disposal regulations must be observed. Also observe the relevant safety instructions in the product documentation. The improper disposal of hazardous substances or fuels can cause health problems and lead to environmental damage.

For additional information about environmental protection, visit the Rohde & Schwarz website.

Instrucciones de seguridad elementales

¡Es imprescindible leer y cumplir las siguientes instrucciones e informaciones de seguridad!

El principio del grupo de empresas Rohde & Schwarz consiste en tener nuestros productos siempre al día con los estándares de seguridad y de ofrecer a nuestros clientes el máximo grado de seguridad. Nuestros productos y todos los equipos adicionales son siempre fabricados y examinados según las normas de seguridad vigentes. Nuestro sistema de garantía de calidad controla constantemente que sean cumplidas estas normas. El presente producto ha sido fabricado y examinado según el certificado de conformidad adjunto de la UE y ha salido de nuestra planta en estado impecable según los estándares técnicos de seguridad. Para poder preservar este estado y garantizar un funcionamiento libre de peligros, el usuario deberá atenerse a todas las indicaciones, informaciones de seguridad y notas de alerta. El grupo de empresas Rohde & Schwarz está siempre a su disposición en caso de que tengan preguntas referentes a estas informaciones de seguridad.













Además queda en la responsabilidad del usuario utilizar el producto en la forma debida. Este producto está destinado exclusivamente al uso en la industria y el laboratorio o, si ha sido expresamente autorizado, para aplicaciones de campo y de ninguna manera deberá ser utilizado de modo que alguna persona/cosa pueda sufrir daño. El uso del producto fuera de sus fines definidos o sin tener en cuenta las instrucciones del fabricante queda en la responsabilidad del usuario. El fabricante no se hace en ninguna forma responsable de consecuencias a causa del mal uso del producto.

Instrucciones de seguridad elementales



Se parte del uso correcto del producto para los fines definidos si el producto es utilizado conforme a las indicaciones de la correspondiente documentación del producto y dentro del margen de rendimiento definido (ver hoja de datos, documentación, informaciones de seguridad que siguen). El uso del producto hace necesarios conocimientos técnicos y ciertos conocimientos del idioma inglés. Por eso se debe tener en cuenta que el producto solo pueda ser operado por personal especializado o personas instruidas en profundidad con las capacidades correspondientes. Si fuera necesaria indumentaria de seguridad para el uso de productos de Rohde & Schwarz, encontraría la información debida en la documentación del producto en el capítulo correspondiente. Guarde bien las informaciones de seguridad elementales, así como la documentación del producto, y entréguelas a usuarios posteriores.

Tener en cuenta las informaciones de seguridad sirve para evitar en lo posible lesiones o daños por peligros de toda clase. Por eso es imprescindible leer detalladamente y comprender por completo las siguientes informaciones de seguridad antes de usar el producto, y respetarlas durante el uso del producto. Deberán tenerse en cuenta todas las demás informaciones de seguridad, como p. ej. las referentes a la protección de personas, que encontrarán en el capítulo correspondiente de la documentación del producto y que también son de obligado cumplimiento. En las presentes informaciones de seguridad se recogen todos los objetos que distribuye el grupo de empresas Rohde & Schwarz bajo la denominación de "producto", entre ellos también aparatos, instalaciones así como toda clase de accesorios. Los datos específicos del producto figuran en la hoja de datos y en la documentación del producto.

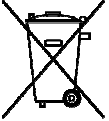
Símbolos y definiciones de seguridad

Símbolo	Significado	Símbolo	Significado
	Aviso: punto de peligro general Observar la documentación del producto		Tensión de alimentación de PUESTA EN MARCHA / PARADA
	Atención en el manejo de dispositivos de peso elevado		Indicación de estado de espera (standby)
	Peligro de choque eléctrico		Corriente continua (DC)
	Advertencia: superficie caliente		Corriente alterna (AC)
	Conexión a conductor de protección		Corriente continua / Corriente alterna (DC/AC)
	Conexión a tierra		El aparato está protegido en su totalidad por un aislamiento doble (reforzado)
	Conexión a masa		Distintivo de la UE para baterías y acumuladores Más información en la sección "Eliminación/protección del medio ambiente", punto 1.

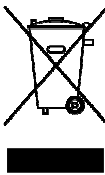
Instrucciones de seguridad elementales

Símbolo	Significado	Símbolo	Significado
	Aviso: Cuidado en el manejo de dispositivos sensibles a la electrostática (ESD)		Distintivo de la UE para la eliminación por separado de dispositivos eléctricos y electrónicos Más información en la sección "Eliminación/protección del medio ambiente", punto 2.
	Advertencia: rayo láser Más información en la sección "Funcionamiento", punto 7.		

Palabras de señal y su significado

En la documentación del producto se utilizan las siguientes palabras de señal con el fin de advertir contra riesgos y peligros.



PELIGRO identifica un peligro inminente con riesgo elevado que provocará muerte o lesiones graves si no se evita.



ADVERTENCIA identifica un posible peligro con riesgo medio de provocar muerte o lesiones (graves) si no se evita.



ATENCIÓN identifica un peligro con riesgo reducido de provocar lesiones leves o moderadas si no se evita.



AVISO indica la posibilidad de utilizar mal el producto y, como consecuencia, dañarlo.
En la documentación del producto se emplea de forma sinónima el término CUIDADO.

Las palabras de señal corresponden a la definición habitual para aplicaciones civiles en el área económica europea. Pueden existir definiciones diferentes a esta definición en otras áreas económicas o en aplicaciones militares. Por eso se deberá tener en cuenta que las palabras de señal aquí descritas sean utilizadas siempre solamente en combinación con la correspondiente documentación del producto y solamente en combinación con el producto correspondiente. La utilización de las palabras de señal en combinación con productos o documentaciones que no les correspondan puede llevar a interpretaciones equivocadas y tener por consecuencia daños en personas u objetos.

Estados operativos y posiciones de funcionamiento

El producto solamente debe ser utilizado según lo indicado por el fabricante respecto a los estados operativos y posiciones de funcionamiento sin que se obstruya la ventilación. Si no se siguen las indicaciones del fabricante, pueden producirse choques eléctricos, incendios y/o lesiones graves con posible consecuencia de muerte. En todos los trabajos deberán ser tenidas en cuenta las normas nacionales y locales de seguridad del trabajo y de prevención de accidentes.

Instrucciones de seguridad elementales

1. Si no se convino de otra manera, es para los productos Rohde & Schwarz válido lo que sigue: como posición de funcionamiento se define por principio la posición con el suelo de la caja para abajo, modo de protección IP 2X, uso solamente en estancias interiores, utilización hasta 2000 m sobre el nivel del mar, transporte hasta 4500 m sobre el nivel del mar. Se aplicará una tolerancia de $\pm 10\%$ sobre el voltaje nominal y de $\pm 5\%$ sobre la frecuencia nominal. Categoría de sobrecarga eléctrica 2, índice de suciedad 2.
2. No sitúe el producto encima de superficies, vehículos, estantes o mesas, que por sus características de peso o de estabilidad no sean aptos para él. Siga siempre las instrucciones de instalación del fabricante cuando instale y asegure el producto en objetos o estructuras (p. ej. paredes y estantes). Si se realiza la instalación de modo distinto al indicado en la documentación del producto, se pueden causar lesiones o, en determinadas circunstancias, incluso la muerte.
3. No ponga el producto sobre aparatos que generen calor (p. ej. radiadores o calefactores). La temperatura ambiente no debe superar la temperatura máxima especificada en la documentación del producto o en la hoja de datos. En caso de sobrecalentamiento del producto, pueden producirse choques eléctricos, incendios y/o lesiones graves con posible consecuencia de muerte.

Seguridad eléctrica

Si no se siguen (o se siguen de modo insuficiente) las indicaciones del fabricante en cuanto a seguridad eléctrica, pueden producirse choques eléctricos, incendios y/o lesiones graves con posible consecuencia de muerte.

1. Antes de la puesta en marcha del producto se deberá comprobar siempre que la tensión preseleccionada en el producto coincida con la de la red de alimentación eléctrica. Si es necesario modificar el ajuste de tensión, también se deberán cambiar en caso dado los fusibles correspondientes del producto.
2. Los productos de la clase de protección I con alimentación móvil y enchufe individual solamente podrán enchufarse a tomas de corriente con contacto de seguridad y con conductor de protección conectado.
3. Queda prohibida la interrupción intencionada del conductor de protección, tanto en la toma de corriente como en el mismo producto. La interrupción puede tener como consecuencia el riesgo de que el producto sea fuente de choques eléctricos. Si se utilizan cables alargadores o regletas de enchufe, deberá garantizarse la realización de un examen regular de los mismos en cuanto a su estado técnico de seguridad.
4. Si el producto no está equipado con un interruptor para desconectarlo de la red, o bien si el interruptor existente no resulta apropiado para la desconexión de la red, el enchufe del cable de conexión se deberá considerar como un dispositivo de desconexión. El dispositivo de desconexión se debe poder alcanzar fácilmente y debe estar siempre bien accesible. Si, p. ej., el enchufe de conexión a la red es el dispositivo de desconexión, la longitud del cable de conexión no debe superar 3 m). Los interruptores selectores o electrónicos no son aptos para el corte de la red eléctrica. Si se integran productos sin interruptor en bastidores o instalaciones, se deberá colocar el interruptor en el nivel de la instalación.
5. No utilice nunca el producto si está dañado el cable de conexión a red. Compruebe regularmente el correcto estado de los cables de conexión a red. Asegúrese, mediante las medidas de protección y de instalación adecuadas, de que el cable de conexión a red no pueda ser dañado o de que nadie pueda ser dañado por él, p. ej. al tropezar o por un choque eléctrico.

Instrucciones de seguridad elementales

6. Solamente está permitido el funcionamiento en redes de alimentación TN/TT aseguradas con fusibles de 16 A como máximo (utilización de fusibles de mayor amperaje solo previa consulta con el grupo de empresas Rohde & Schwarz).
7. Nunca conecte el enchufe en tomas de corriente sucias o llenas de polvo. Introduzca el enchufe por completo y fuertemente en la toma de corriente. La no observación de estas medidas puede provocar chispas, fuego y/o lesiones.
8. No sobrecargue las tomas de corriente, los cables alargadores o las regletas de enchufe ya que esto podría causar fuego o choques eléctricos.
9. En las mediciones en circuitos de corriente con una tensión $U_{\text{eff}} > 30 \text{ V}$ se deberán tomar las medidas apropiadas para impedir cualquier peligro (p. ej. medios de medición adecuados, seguros, limitación de tensión, corte protector, aislamiento etc.).
10. Para la conexión con dispositivos informáticos como un PC o un ordenador industrial, debe comprobarse que éstos cumplan los estándares IEC60950-1/EN60950-1 o IEC61010-1/EN 61010-1 válidos en cada caso.
11. A menos que esté permitido expresamente, no retire nunca la tapa ni componentes de la carcasa mientras el producto esté en servicio. Esto pone a descubierto los cables y componentes eléctricos y puede causar lesiones, fuego o daños en el producto.
12. Si un producto se instala en un lugar fijo, se deberá primero conectar el conductor de protección fijo con el conductor de protección del producto antes de hacer cualquier otra conexión. La instalación y la conexión deberán ser efectuadas por un electricista especializado.
13. En el caso de dispositivos fijos que no estén provistos de fusibles, interruptor automático ni otros mecanismos de seguridad similares, el circuito de alimentación debe estar protegido de modo que todas las personas que puedan acceder al producto, así como el producto mismo, estén a salvo de posibles daños.
14. Todo producto debe estar protegido contra sobretensión (debida p. ej. a una caída del rayo) mediante los correspondientes sistemas de protección. Si no, el personal que lo utilice quedará expuesto al peligro de choque eléctrico.
15. No debe introducirse en los orificios de la caja del aparato ningún objeto que no esté destinado a ello. Esto puede producir cortocircuitos en el producto y/o puede causar choques eléctricos, fuego o lesiones.
16. Salvo indicación contraria, los productos no están impermeabilizados (ver también el capítulo "Estados operativos y posiciones de funcionamiento", punto 1). Por eso es necesario tomar las medidas necesarias para evitar la entrada de líquidos. En caso contrario, existe peligro de choque eléctrico para el usuario o de daños en el producto, que también pueden redundar en peligro para las personas.
17. No utilice el producto en condiciones en las que pueda producirse o ya se hayan producido condensaciones sobre el producto o en el interior de éste, como p. ej. al desplazarlo de un lugar frío a otro caliente. La entrada de agua aumenta el riesgo de choque eléctrico.
18. Antes de la limpieza, desconecte por completo el producto de la alimentación de tensión (p. ej. red de alimentación o batería). Realice la limpieza de los aparatos con un paño suave, que no se deshilache. No utilice bajo ningún concepto productos de limpieza químicos como alcohol, acetona o diluyentes para lacas nitrocelulósicas.

Instrucciones de seguridad elementales

Funcionamiento

1. El uso del producto requiere instrucciones especiales y una alta concentración durante el manejo. Debe asegurarse que las personas que manejen el producto estén a la altura de los requerimientos necesarios en cuanto a aptitudes físicas, psíquicas y emocionales, ya que de otra manera no se pueden excluir lesiones o daños de objetos. El empresario u operador es responsable de seleccionar el personal usuario apto para el manejo del producto.
2. Antes de desplazar o transportar el producto, lea y tenga en cuenta el capítulo "Transporte".
3. Como con todo producto de fabricación industrial no puede quedar excluida en general la posibilidad de que se produzcan alergias provocadas por algunos materiales empleados —los llamados alérgenos (p. ej. el níquel)—. Si durante el manejo de productos Rohde & Schwarz se producen reacciones alérgicas, como p. ej. irritaciones cutáneas, estornudos continuos, enrojecimiento de la conjuntiva o dificultades respiratorias, debe avisarse inmediatamente a un médico para investigar las causas y evitar cualquier molestia o daño a la salud.
4. Antes de la manipulación mecánica y/o térmica o el desmontaje del producto, debe tenerse en cuenta imprescindiblemente el capítulo "Eliminación/protección del medio ambiente", punto 1.
5. Ciertos productos, como p. ej. las instalaciones de radiocomunicación RF, pueden a causa de su función natural, emitir una radiación electromagnética aumentada. Deben tomarse todas las medidas necesarias para la protección de las mujeres embarazadas. También las personas con marcapasos pueden correr peligro a causa de la radiación electromagnética. El empresario/operador tiene la obligación de evaluar y señalar las áreas de trabajo en las que exista un riesgo elevado de exposición a radiaciones.
6. Tenga en cuenta que en caso de incendio pueden desprenderse del producto sustancias tóxicas (gases, líquidos etc.) que pueden generar daños a la salud. Por eso, en caso de incendio deben usarse medidas adecuadas, como p. ej. máscaras antigás e indumentaria de protección.
7. Los productos con láser están provistos de indicaciones de advertencia normalizadas en función de la clase de láser del que se trate. Los rayos láser pueden provocar daños de tipo biológico a causa de las propiedades de su radiación y debido a su concentración extrema de potencia electromagnética. En caso de que un producto Rohde & Schwarz contenga un producto láser (p. ej. un lector de CD/DVD), no debe usarse ninguna otra configuración o función aparte de las descritas en la documentación del producto, a fin de evitar lesiones (p. ej. debidas a irradiación láser).
8. Clases CEM (según CISPR 11)
Clase A: dispositivo apropiado para el uso en cualquier zona excepto en áreas residenciales y en aquellas zonas que se encuentran conectadas a una red de suministro de baja tensión que alimenta un edificio de viviendas.
Clase B: dispositivo apropiado para el uso en áreas residenciales y en aquellas zonas que se encuentran conectadas a una red de suministro de baja tensión que alimenta un edificio de viviendas.

Reparación y mantenimiento

1. El producto solamente debe ser abierto por personal especializado con autorización para ello. Antes de manipular el producto o abrirlo, es obligatorio desconectarlo de la tensión de alimentación, para evitar toda posibilidad de choque eléctrico.

Instrucciones de seguridad elementales

2. El ajuste, el cambio de partes, el mantenimiento y la reparación deberán ser efectuadas solamente por electricistas autorizados por Rohde & Schwarz. Si se reponen partes con importancia para los aspectos de seguridad (p. ej. el enchufe, los transformadores o los fusibles), solamente podrán ser sustituidos por partes originales. Después de cada cambio de partes relevantes para la seguridad deberá realizarse un control de seguridad (control a primera vista, control del conductor de protección, medición de resistencia de aislamiento, medición de la corriente de fuga, control de funcionamiento). Con esto queda garantizada la seguridad del producto.

Baterías y acumuladores o celdas

Si no se siguen (o se siguen de modo insuficiente) las indicaciones en cuanto a las baterías y acumuladores o celdas, pueden producirse explosiones, incendios y/o lesiones graves con posible consecuencia de muerte. El manejo de baterías y acumuladores con electrolitos alcalinos (p. ej. celdas de litio) debe seguir el estándar EN 62133.

1. No deben desmontarse, abrirse ni triturarse las celdas.
2. Las celdas o baterías no deben someterse a calor ni fuego. Debe evitarse el almacenamiento a la luz directa del sol. Las celdas y baterías deben mantenerse limpias y secas. Limpiar las conexiones sucias con un paño seco y limpio.
3. Las celdas o baterías no deben cortocircuitarse. Es peligroso almacenar las celdas o baterías en estuches o cajones en cuyo interior puedan cortocircuitarse por contacto recíproco o por contacto con otros materiales conductores. No deben extraerse las celdas o baterías de sus embalajes originales hasta el momento en que vayan a utilizarse.
4. Las celdas o baterías no deben someterse a impactos mecánicos fuertes indebidos.
5. En caso de falta de estanqueidad de una celda, el líquido vertido no debe entrar en contacto con la piel ni los ojos. Si se produce contacto, lavar con agua abundante la zona afectada y avisar a un médico.
6. En caso de cambio o recarga inadecuados, las celdas o baterías que contienen electrolitos alcalinos (p. ej. las celdas de litio) pueden explotar. Para garantizar la seguridad del producto, las celdas o baterías solo deben ser sustituidas por el tipo Rohde & Schwarz correspondiente (ver lista de recambios).
7. Las baterías y celdas deben reciclarse y no deben tirarse a la basura doméstica. Las baterías o acumuladores que contienen plomo, mercurio o cadmio deben tratarse como residuos especiales. Respete en esta relación las normas nacionales de eliminación y reciclaje.

Transporte

1. El producto puede tener un peso elevado. Por eso es necesario desplazarlo o transportarlo con precaución y, si es necesario, usando un sistema de elevación adecuado (p. ej. una carretilla elevadora), a fin de evitar lesiones en la espalda u otros daños personales.
2. Las asas instaladas en los productos sirven solamente de ayuda para el transporte del producto por personas. Por eso no está permitido utilizar las asas para la sujeción en o sobre medios de transporte como p. ej. grúas, carretillas elevadoras de horquilla, carros etc. Es responsabilidad suya fijar los productos de manera segura a los medios de transporte o elevación. Para evitar daños personales o daños en el producto, siga las instrucciones de seguridad del fabricante del medio de transporte o elevación utilizado.

Instrucciones de seguridad elementales

3. Si se utiliza el producto dentro de un vehículo, recae de manera exclusiva en el conductor la responsabilidad de conducir el vehículo de manera segura y adecuada. El fabricante no asumirá ninguna responsabilidad por accidentes o colisiones. No utilice nunca el producto dentro de un vehículo en movimiento si esto pudiera distraer al conductor. Asegure el producto dentro del vehículo debidamente para evitar, en caso de un accidente, lesiones u otra clase de daños.

Eliminación/protección del medio ambiente

1. Los dispositivos marcados contienen una batería o un acumulador que no se debe desechar con los residuos domésticos sin clasificar, sino que debe ser recogido por separado. La eliminación se debe efectuar exclusivamente a través de un punto de recogida apropiado o del servicio de atención al cliente de Rohde & Schwarz.
2. Los dispositivos eléctricos usados no se deben desechar con los residuos domésticos sin clasificar, sino que deben ser recogidos por separado. Rohde & Schwarz GmbH & Co.KG ha elaborado un concepto de eliminación de residuos y asume plenamente los deberes de recogida y eliminación para los fabricantes dentro de la UE. Para desechar el producto de manera respetuosa con el medio ambiente, diríjase a su servicio de atención al cliente de Rohde & Schwarz.
3. Si se trabaja de manera mecánica y/o térmica cualquier producto o componente más allá del funcionamiento previsto, pueden liberarse sustancias peligrosas (povos con contenido de metales pesados como p. ej. plomo, berilio o níquel). Por eso el producto solo debe ser desmontado por personal especializado con formación adecuada. Un desmontaje inadecuado puede ocasionar daños para la salud. Se deben tener en cuenta las directivas nacionales referentes a la eliminación de residuos.
4. En caso de que durante el trato del producto se formen sustancias peligrosas o combustibles que deban tratarse como residuos especiales (p. ej. refrigerantes o aceites de motor con intervalos de cambio definidos), deben tenerse en cuenta las indicaciones de seguridad del fabricante de dichas sustancias y las normas regionales de eliminación de residuos. Tenga en cuenta también en caso necesario las indicaciones de seguridad especiales contenidas en la documentación del producto. La eliminación incorrecta de sustancias peligrosas o combustibles puede causar daños a la salud o daños al medio ambiente.

Se puede encontrar más información sobre la protección del medio ambiente en la página web de Rohde & Schwarz.

Instructions for Electrostatic Discharge Protection

NOTICE

Risk of damaging electronic components

To avoid damage of electronic components, the operational site must be protected against electrostatic discharge (ESD).

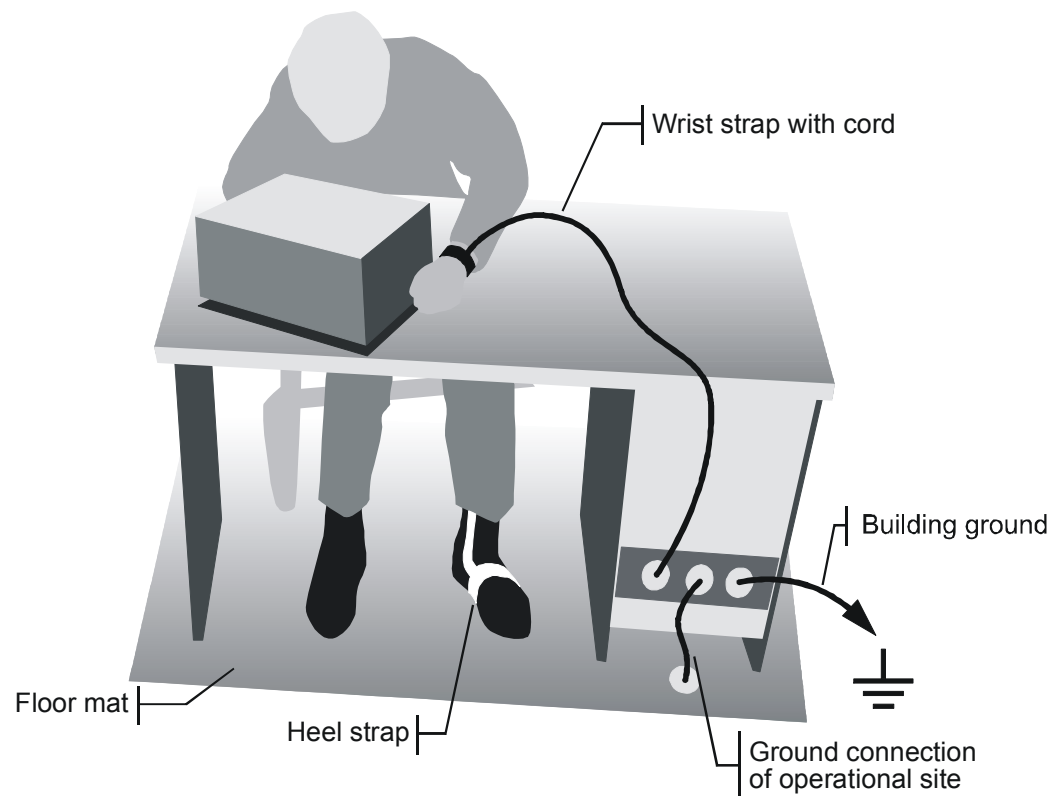

The following two methods of ESD protection may be used together or separately:

- Wrist strap with cord to ground connection
 - Conductive floor mat and heel strap combination
-

Instrucciones para la protección contra descargas electrostáticas

AVISO

Riesgo de avería de los componentes electrónicos

Para evitar averías en los componentes electrónicos, el área de trabajo tiene que estar protegido contra descargas electrostáticas ESD (electrostatic discharge).

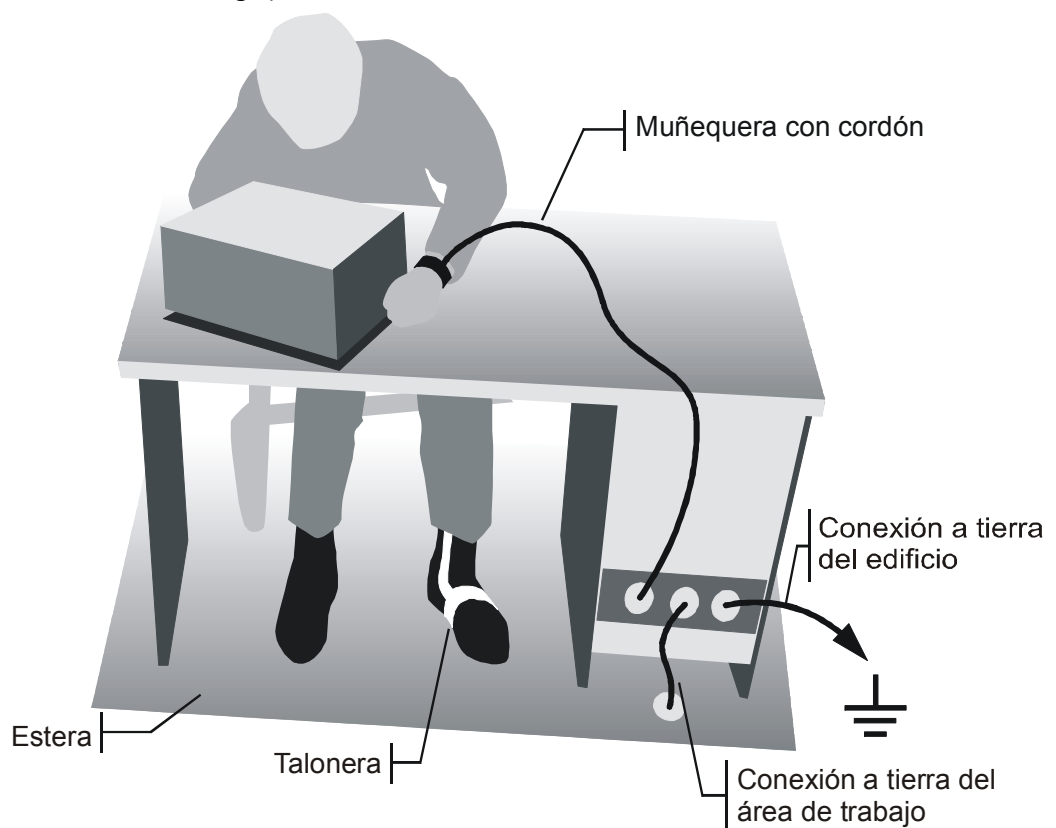

Los siguientes dos métodos de protección ESD pueden ser usados juntos o separados:

- Muñequera con cordón para conexión a tierra
- Combinación de estera antiestática y talonera

Procedure in Case of Service and Ordering of Spare Parts

This section contains information on shipping an instrument to your service center and ordering spare parts.

Please contact your local Rohde & Schwarz service center if you need service or repair work of your equipment or to order spare parts. The list of the Rohde & Schwarz representatives is provided at the beginning of this service manual. You can find the current address of your representative on our homepage www.rohde-schwarz.com. Navigate to Service & Support / Service Locations.

Shipping the Instrument

We require the following information in order to answer your inquiry fast and correctly and to determine whether the warranty is still valid for your instrument:

- Instrument model
- Serial number
- Firmware version
- Must the instrument be returned with this firmware?
- Detailed error description in case of repair
- Indication of desired calibration
- Contact person for possible questions

In some countries, an RMA process is available for the return shipment of the instrument. For details, contact your local representative.

When shipping the instrument, be careful to provide for sufficient mechanical and antistatic protection.

- Use the original packaging for transporting or shipping the instrument. The protective caps for the front and rear prevent damage to the operating elements and the connectors.
- If you do not use the original packaging, provide for sufficient padding to prevent the instrument from slipping inside the box. Wrap antistatic packing foil around the instrument to protect it from electrostatic charging.

Rohde & Schwarz offers repair and calibrations of the test systems it produces. The calibration documentation fulfills ISO 17025 requirements.

Shipping Defective Modules

Also when shipping a module, be careful to provide for sufficient mechanical and antistatic protection.

- Ship the module in a sturdy, padded box.
- Wrap the module in antistatic foil.

If the packaging is only antistatic but not conductive, additional conductive packaging is required. The additional packaging is not required if the tightly fitting packaging is conductive.

Exception:

If the module contains a battery, the tightly fitting packaging must always consist of antistatic, non-chargeable material to protect the battery from being discharged.

Ordering Spare Parts

To deliver spare parts promptly and correctly, we need the following information:

- Stock number (see list of spare parts in chapter "Documents")
- Designation
- Component number according to list of spare parts
- Number of pieces
- Instrument type for which the spare part is needed
- Instrument stock number
- Instrument serial number
- Contact person for possible questions

Refurbished Modules

Refurbished modules are an economical alternative to original modules. Bear in mind that refurbished modules are not new, but repaired and fully tested parts. They may have traces from use, but they are electrically and mechanically equivalent to new modules.

Your Rohde & Schwarz representative will be happy to inform you about which modules are available as refurbished modules.

Taking Back Defective Replaced Modules

Defective modules of the replacement program which cannot be repaired are taken back within three months following delivery. A repurchasing value is credited.

Excluded are parts which cannot be repaired, e.g. printed boards that are burnt, broken or damaged by attempts to repair them, incomplete modules, and parts with severe mechanical damage.

Please return the defective replacement modules, together with the accompanying document for returned merchandise, which you received with the spare module. We need the following information:

- Stock number, serial number and designation of the removed part
- Detailed error description
- Stock number, serial number and type of instrument from which the module was removed
- Date of removal
- Name of the engineer/technician who replaced the module
- R&S ordering number
- Service reference number (if available)

Table of Contents

1	Performance Test	8
1.1	Test Equipment	8
1.2	Test Assemblies	10
1.2.1	Test Assembly for SSB Phase Noise and Jitter	10
1.2.2	Test Assembly for Output Impedance (VSWR).....	11
1.2.3	Test Assembly for Setting Time.....	11
1.2.4	Test Assembly for I/Q Modulation	12
1.3	Preparation, Recommended Test Frequencies and Levels	13
1.4	Test Procedures	14
1.4.1	Reference Frequency.....	14
1.4.1.1	Internal Reference Mode.....	14
1.4.1.2	External Reference mode	15
1.4.2	Frequency	16
1.4.2.1	Frequency Setting	16
1.4.2.2	Setting Time	16
1.4.3	Spectral Purity	20
1.4.3.1	Harmonics.....	20
1.4.3.2	Subharmonics	21
1.4.3.3	Nonharmonics	21
1.4.3.4	Non-systematic nonharmonics.....	23
1.4.3.5	Wideband Noise.....	24
1.4.3.6	SSB Phase Noise.....	26
1.4.3.7	Residual FM	29
1.4.3.8	Residual AM	31
1.4.4	Level Data	33
1.4.4.1	Level Uncertainty	33
1.4.4.2	Output Impedance.....	35
1.4.4.3	Setting Time	36
1.4.5	I/Q modulation.....	38
1.4.5.1	Input Impedance (VSWR).....	38
1.4.5.2	Error Vector	39

1.4.5.3	Residual Carrier and Leakage	40
1.4.5.4	I/Q Imbalance	41
1.4.5.5	Adjacent Channel Power for 3GPP FDD	42
1.4.5.6	Frequency Response of Baseband Bypass path.....	43
1.4.5.7	Level linearity of Baseband Bypass path	44
1.4.6	Phase Coherence Levels (Option R&S SGS-K90)	45
1.4.7	PCI Express Interface	45
2	Adjustment	46
2.1	Procedures after Module Replacement	46
2.1.1	Restore Ethernet MAC Adress	47
2.2	Adding Hardware Options.....	47
2.3	Internal Adjustments.....	49
2.4	External Adjustments Requiring Measurement Equipment	49
2.5	Adjustment of internal Reference Frequency	49
2.5.1	Adjustment	50
2.6	Internal Self Test	50
3	Repair	51
3.1	Functional Description	52
3.1.1	Power Supply Module	52
3.1.2	Controller Board	52
3.1.2.1	Switching regulators.....	52
3.1.2.2	Controller.....	52
3.1.2.3	FPGA (SIGMA_COM)	52
3.1.2.4	Diagnostic Multiplexer	52
3.1.2.5	EEPROM.....	52
3.1.2.6	Temperature sensor	53
3.1.3	RF Mainboard	53
3.1.3.1	Block diagram	53
3.1.3.2	Implemented functions	54
3.1.3.3	Internal and external reference	54
3.1.3.4	Main 1000 MHz oscillator.....	54
3.1.3.5	RF Synthesizer/ DDS module	54
3.1.3.6	Vector modulator	55

3.1.3.7	Harmonics filters	55
3.1.3.8	Automatic Level control.....	55
3.1.3.9	Fan Controller	55
3.1.3.10	Supply voltage control and filtering	55
3.1.4	Doubler Board	56
3.1.4.1	Doubler Board architecture	56
3.1.4.2	Doubler Board diagram	56
3.1.5	Step Attenuator.....	57
3.1.5.1	Step Attenuator architecture.....	57
3.1.5.2	Step Attenuator diagram	57
3.1.5.3	Power Amplifiers	57
3.1.5.4	Voltage Regulators and filtering	57
3.1.6	R&S SGS-B1 Reference Oscillator.....	58
3.2	Troubleshooting	59
3.2.1	Measuring Equipment and Accessories.....	60
3.2.2	Switch-On Problems	60
3.2.3	Keyboard and LED Test	62
3.2.4	Troubleshooting with Internal Selftest.....	63
3.2.5	Troubleshooting with Internal Adjustments	64
3.2.6	Instrument Faults	65
3.2.6.1	Fuses	71
3.2.7	Troubleshooting – RF Mainboard	73
3.2.7.1	Internal Adjustment “Adjust All”	73
3.2.7.2	Supply Voltages	74
3.2.7.3	Input and Output Signals.....	75
3.2.7.4	Error Messages Concerning the RF Mainboard	77
3.2.7.5	Warnings Concerning the RF Mainboard.....	77
3.2.7.6	Frequency Error	78
3.2.8	Troubleshooting – Reference Oscillator option R&S SGS-B1	78
3.2.8.1	Input and Output Signals.....	78
3.2.8.2	Error Messages Concerning the Reference Oscillator Module.....	80
3.2.8.3	Frequency Error, Reference Oscillator Adjustment.....	81
3.2.9	Troubleshooting – Active Step Attenuator	81

3.2.9.1	Supply Voltages	81
3.2.10	Troubleshooting – Doubler Board option R&S SGS-B112/-B112V	83
3.2.10.1	Supply Voltages	83
3.2.10.2	Input and Output Signals.....	84
3.3	Module Replacement and Upgrade	85
3.3.1	Required Tools	85
3.3.2	Module Overview	86
3.3.3	After Replacing an Assembly	86
3.3.4	Removing the Case.....	87
3.3.5	Installing the Case.....	88
3.3.6	Replacing the EMC Panel.....	89
3.3.6.1	Removing the EMC Panel.....	89
3.3.6.2	Installing the EMC Panel.....	89
3.3.7	Replacing the Power Supply (A50).....	90
3.3.7.1	Removing the Power Supply.....	90
3.3.7.2	Installing the Power Supply (A50).....	92
3.3.8	Replacing the RF Mainboard (A200)	93
3.3.8.1	Removing the RF Mainboard	93
3.3.8.2	Installing the RF Mainboard (A200).....	95
3.3.9	Replacing the Controller Board A100.....	98
3.3.9.1	Removing the Controller	98
3.3.9.2	Installing the Controller (A100).....	100
3.3.9.3	Replacing the SIM Card.....	102
3.3.10	Replacing the Front Unit	102
3.3.10.1	Removing the Front Unit	102
3.3.11	Replacing the Flex Switch Board A300.....	104
3.3.11.1	Removing the Flex Switch Board and Push-Button Board	104
3.3.11.2	Installing the Flex Switch Board and the Push-Button Board	106
3.3.12	Replacing the Fan E1.....	108
3.3.13	Replacing the OCXO Board R&S SGS-B1	110
3.3.13.1	Removing the OCXO Board.....	110
3.3.13.2	Installing the OCXO Board.....	111
3.3.14	Replacing the Doubler Board - R&S SGS-B112/-B112V (A400)	111

3.3.14.1	Removing the Doubler Board.....	111
3.3.14.2	Installing the Doubler Board.....	113
3.3.15	Replacing the Electronic Step Attenuator R&S SGS-B26).....	115
3.3.15.1	Removing the Electronic Step Attenuator	115
3.3.15.2	Installing the Electronic Step Attenuator	116
4	Firmware Update	118
5	Factory Recover and USB Install	119
6	Documents	120
6.1	Spare Parts.....	120
6.1.1	Available Power Cables	120
6.2	Spare Part List and Mechanical Drawings.....	121
Index	122

1 Performance Test

Test Instructions

To ensure that rated specifications are maintained, the following preparations must be made prior to checking the rated characteristics:

- Check the instrument condition. Make sure the instrument fan operation is not constrained by dust etc. The fan can be inspected through the air intake at the case bottom side.
- Allow for a minimum warm-up time of 30 minutes at ambient temperature.
- Carry out all internal adjustments.
- The values are specified in the data sheet. Additional uncertainties introduced by the measurement equipment must be taken into account when checking the rated values.

This performance test describes the steps for testing the R&S SGS100A Signal Generator family and the installed options with respect to function and compliance with specifications.

In the following, the term DUT (Device Under Test) is used for any signal generator of this family. The tests to be performed depend on the installed options. The values are given in the data sheet of the respective instrument.

1.1 Test Equipment

Table 1-1 Measuring equipment and accessories

Item	Type of equipment	Recommended characteristics or features	Recommended model	R&S Order No.
1	Frequency counter	1 Hz to RFmax, resolution 0.1 Hz (included in RF analyzer item 19)		
2	Reference source for SSB noise measurements	Identical generator as DUT or generator with at least 10 dB lower SSB noise as DUT Frequency range up to RFmax	R&S SGS100A with adequate frequency option or R&S SMF100A only for $f \geq 1000$ MHz or R&S SMA100A with option R&S SMA-B106 and option R&S SMA-B22 only for $f \leq 6000$ MHz	1416.0505.02 1158.2878 1167.0000.02 1400.0000K02 1405.0809.02 1405.1805.02

4	Controller	Industry standard PC/XT/AT with IEC-60625 interface and USB interface and LAN interface and optional PCI Express interface		
5	Signal generator	1 MHz to RFmax	R&S SMB100A with adequate frequency option or R&S SMF100A with option R&S SMF-B2	1406.6000K03 1167.0000K02 1167.4005.02
6	Phase noise test assembly	Phase Noise Test Set or Mixer: 10 MHz to RFmax, branching filter 20 MHz, DC decoupling after the mixer	R&S FSUP 26 or R&S FSUP 50 or Mixer: f < 1 GHz: Minicircuits ZFM2H 1 GHz < f < 13 GHz: Miteq DB0118LA2	1166.3505.27 1166.3505.51
7	Oscilloscope	Bandwidth \geq 100 MHz, two channels with DC coupling	Hameg HM1500-2 or similar	
8	RF power meter	1 MHz to RFmax	R&S NRP with R&S NRP-Z55 or R&S NRP-Z51	1143.8500.02 1138.2008.02 1138.0005.0x
9	Low-noise preamplifier	10 Hz to 10 MHz gain > 20 dB, input noise < 4 nV (1 Hz)		
10	VSWR bridge	1 MHz to RFmax directivity > 30 dB	f < 4 GHz: R&S ZRC 3 GHz f < 12.75 GHz: Agilent 773D	1039.9492.55
14	Arbitrary wave generator	two channels	R&S SMBV R&S SMU	1407.6004K02 1141.2005.02
15	AC/DC voltmeter	10 Hz to 10 MHz	R&S URE3	350.5315.03
16	Broadband FM demodulator	included in RF analyzer item 19		
19	RF analyzer & Demodulator for analog modulations & FM-demodulator	1 MHz to RFmax * 2	R&S FSQ26 with options R&S FSU-B25 R&S FSQ K7	1155.5001.26 1044.9298.02 1141.1796.02

20	Software for simulation of digital modulations	Generation of data for ARB generator	R&S WinIQSIM	
21	Lowpass filter (2 pieces required)	Lowpass filter 2.5 MHz to remove WCDMA I/Q BB test signal noise Passband loss < 0.5 dB for $f = 0 \dots 2$ MHz Stopband loss > 15 dB for $f > 3$ MHz Linearity IP3 > 50 dBm		
23	PCIe cable	PCIe extension cable with single lane connectors, length max. 5 m	One Stop Systems OSS-PCIe-CBL-x1 or equivalent	
24	PCIe device	External single lane PCIe device	R&S PCIe test port	5009.9002.02

1.2 Test Assemblies

1.2.1 Test Assembly for SSB Phase Noise and Jitter

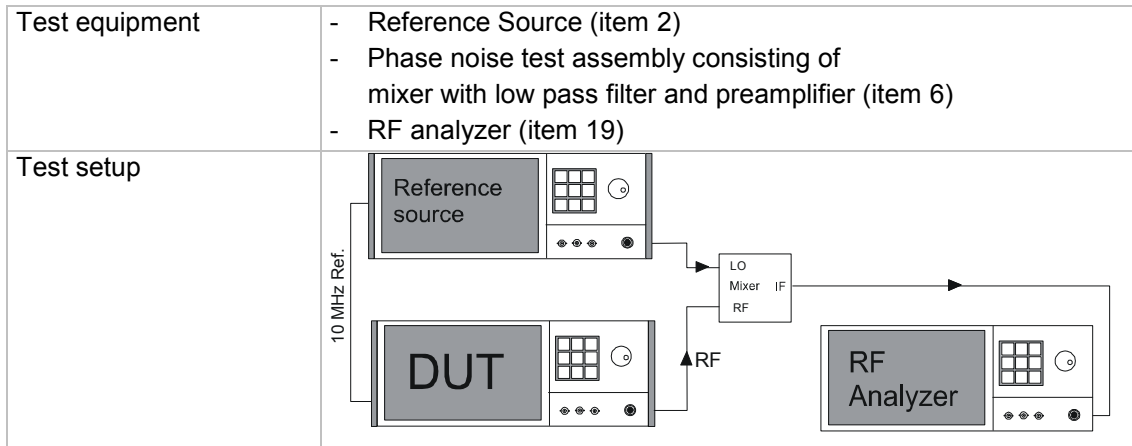

1.2.2 Test Assembly for Output Impedance (VSWR)

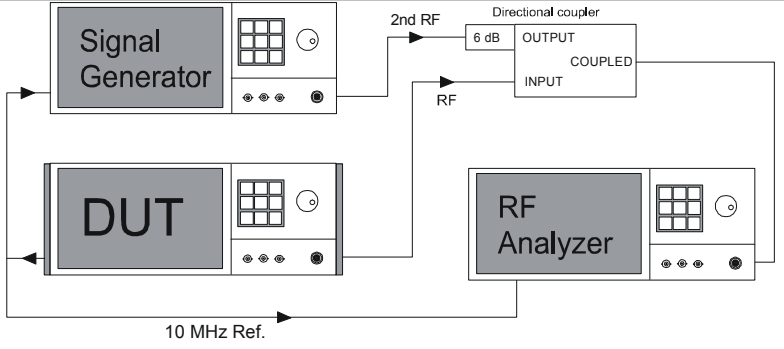
<p>Test equipment</p>	<ul style="list-style-type: none"> - VSWR bridge (item 10) - Signal generator (item 5) - RF analyzer (item 19)
<p>Test setup</p>	
	<p>Note: The INPUT of the directional coupler is directly screwed to the DUT. The second signal generator is connected to the line connector (OUTPUT), the analyzer to the coupling output (COUPLED) of the directional coupler.</p>

1.2.3 Test Assembly for Setting Time

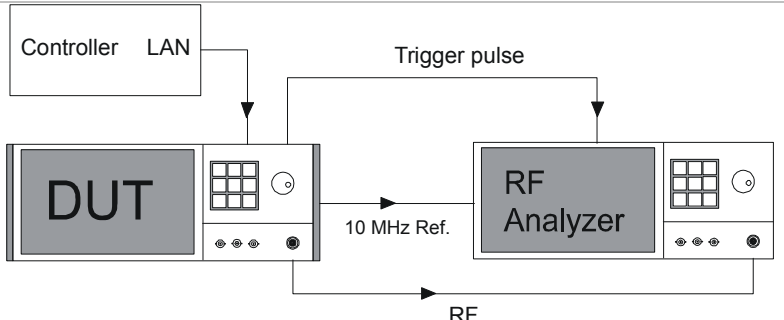
<p>Test equipment</p>	<ul style="list-style-type: none"> - RF analyzer (item 19)
<p>Test setup</p>	

1.2.4 Test Assembly for I/Q Modulation

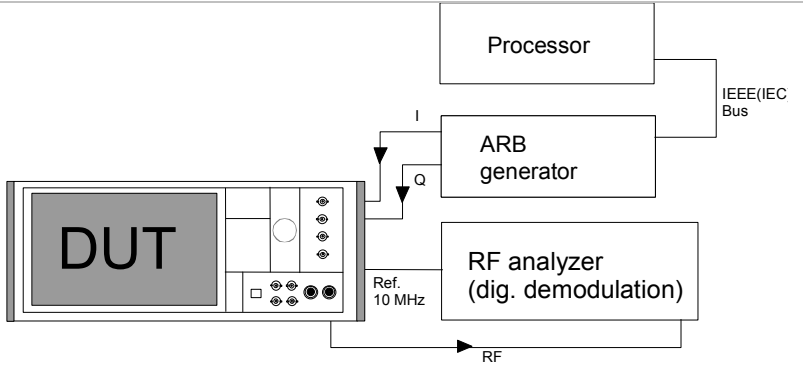
<p>Test equipment</p>	<ul style="list-style-type: none"> - RF analyzer (item 19) - Arbitrary waveform generator (item 14) - Software for simulation of digital modulations (item 20) - Controller (item 4)
<p>Test setup</p>	 <p>The diagram illustrates the test setup for I/Q modulation. It features a central Device Under Test (DUT) with a control panel. To the right of the DUT is an ARB generator, which provides I and Q signals to the DUT. Above the ARB generator is a Processor, connected to it via an IEEE(IEC) Bus. Below the DUT is an RF analyzer (digital demodulation), which provides a 10 MHz reference signal (Ref. 10 MHz) to the DUT and receives an RF signal from the DUT.</p>

1.3 Preparation, Recommended Test Frequencies and Levels

To ensure proper conditions for the performance test and prevent setting errors, the instrument must be prepared as follows:

- Check the instrument condition. Make sure the instrument fan operation is not constrained by dust etc. The fan can be inspected through the air intake at the case bottom side.
- Allow for a minimum **warm-up time of 30 minutes** at ambient temperature.
- Carry out all **internal adjustments** (see operating manual, chapter 4, section "Internal Adjustment - Setup-System").
- Perform Preset to establish a defined **initial** state before configuring a new measurement.

The following sections describe the **procedures** for checking the rated values. The **values** are specified in the **data sheet**. Additional uncertainties introduced by the measurement equipment must be taken into account when checking the rated values.

The following table lists the important internal switch point frequencies and the recommended measurement frequencies derived from these frequencies. We recommend measurements at these frequencies unless particular test frequencies are specified. In the following, RF_{max} is the maximal settable RF (depending on installed options).

Table 1-2 Range limits, main test frequencies for CW Mode

Range	Frequency	Hardware switching points	Recommended test frequencies
Direct DDS Synthesis	$1 \text{ MHz} \leq f \leq 80 \text{ MHz}$	80 MHz	1 MHz; 5.001 MHz; 10.01 MHz; 20.01 MHz; 40.01 MHz; 60.01 MHz; 80 MHz
Divider /64	$80 \text{ MHz} < f \leq 93.75 \text{ MHz}$	93.75 MHz	80.01 MHz; 93.75 MHz
Divider /32	$93.75 \text{ MHz} < f \leq 187.5 \text{ MHz}$	120 MHz; 187.5 MHz	93.76 MHz; 120 MHz; 187.5 MHz
Divider /16	$187.5 \text{ MHz} < f \leq 375 \text{ MHz}$	265 MHz; 375MHz	187.6 MHz; 265 MHz; 375 MHz
Divider /8	$375 \text{ MHz} < f \leq 750 \text{ MHz}$	530MHz; 750MHz	375.1 MHz; 530 MHz; 750 MHz
Divider /4	$750 \text{ MHz} < f \leq 1500 \text{ MHz}$	1060MHz; 1500 MHz	750.1 MHz; 1060 MHz; 1500 MHz
Divider /2	$1500 \text{ MHz} < f \leq 3 \text{ GHz}$	2120 MHz; 3000 MHz	1501 MHz; 2120 MHz; 3000 MHz
Base octave	$3 \text{ GHz} < f \leq 6.5 \text{ GHz}$	4000 MHz, 6000 MHz, 6500 MHz	3001 MHz; 3500 MHz; 4000 MHz; 5100 MHz; 6000 MHz; 6001 MHz; 6500 MHz
Doubler range	$6.5 \text{ GHz} < f \leq 12.75 \text{ GHz}$	7200 MHz, 7300 MHz, 8900 MHz, 9400 MHz, 10700 MHz	6501 MHz; 7200 MHz; 7201 MHz; 7300 MHz; 7301 MHz; 8100 MHz; 8900 MHz; 8901 MHz; 9400 MHz; 9401 MHz; 9800 MHz; 10700 MHz; 10701 MHz; 11700 MHz; 12750 MHz

RF_{max} is the maximum output frequency of the instrument according to its frequency option (6 GHz or 12.75 GHz).

For **high-resolution measurements** in the entire frequency range, a logarithmic frequency grid in 1-2-5 sequence is recommended up to 50 MHz; above this value, linear 50 MHz steps should be used up to the upper limit frequency.

The recommended **test levels** are at the upper and lower switching threshold of the attenuator. The electronic attenuator of the DUT is switched depending on frequency, modulation parameters and level according to an internal stored table in approximately 6 dB steps. The switching thresholds can be detected under **Attenuator fixed range** in the **Level** menu. After setting all other parameters, the threshold level can be detected by level variation.

The level at which the attenuator fixed range changes is the threshold. By measuring at the last level setting of one range and the first level setting of the next range, the internal setting range borders are used. In the following, P_{\max} is the highest level before switching the attenuator, and P_{\min} is defined as $P_{\max} - 7$ dB for the electronic step attenuator R&S SGS-B26.

1.4 Test Procedures

1.4.1 Reference Frequency

1.4.1.1 Internal Reference Mode

Important: Allow the DUT to warm up for at least 2 hours before starting the measurement.

Test equipment	<ul style="list-style-type: none"> - RF power meter, (item 8) - Frequency counter (item 1)
Test setup	<ul style="list-style-type: none"> ➤ Connect an RF power meter to the REF OUT output (on rear panel).
Measurement	<ul style="list-style-type: none"> ➤ Measure the output level. It should be within the data sheet specifications. <p>DUT setting: Internal Reference, Ref Output Frequency set to 10 MHz / 1000 MHz</p>
Test setup	<ul style="list-style-type: none"> ➤ Connect a calibrated frequency counter to the REF OUT output (on rear panel).
Measurement	<ul style="list-style-type: none"> ➤ Measure the frequency. <p>DUT setting: Internal Reference, Reference output set to 10 MHz / 1000 MHz</p> <p>⇒ The frequency deviation must not exceed the sum of deviations resulting from the frequency error in the rated temperature range and from aging.</p>

1.4.1.2 External Reference mode

Test equipment	<ul style="list-style-type: none"> - Frequency counter (item 1) - Signal generator (item 5) - RF power meter (item 8) 																								
Test method	<p>The external reference input frequency of the DUT is varied according to the data sheet and the RF output signal frequency is controlled with a frequency counter to follow this variation. The Reference output level is tested.</p>																								
Preparation of measurement	<ul style="list-style-type: none"> ➤ Connect the signal generator RF output to the REF IN input for the external reference (on rear panel) of the DUT. Connect a calibrated frequency counter to the RF output. Synchronize the signal generator and the frequency counter. <p>Setting on DUT:</p> <ul style="list-style-type: none"> - RF on - Level: 0 dBm (suitable level for the frequency counter) - Frequency: 1 GHz - Setup ⇨ Reference Oscillator <ul style="list-style-type: none"> ⇨ Source: External ⇨ Ext Ref Frequency: 10 MHz ⇨ REF/LO Output: REF ⇨ Output Frequency: 10 MHz <p>Setting on signal generator:</p> <ul style="list-style-type: none"> - RF on - Level: 0 dBm 																								
Measurement	<ul style="list-style-type: none"> ➤ Set the generator frequency to the nominal Ext Ref frequency +/- 10 ppm. Measure the output frequency of the DUT. <p>There must be no relative frequency error and no error message in the display of the DUT.</p> <ul style="list-style-type: none"> ➤ Connect the frequency counter to the DUT Ref Out connector. Measure the Ref Out frequency. There must be no relative frequency error compared to the Ext Ref frequency delivered to the DUT. ➤ Connect a RF power meter to the DUT Ref Out connector. The Ref Out level shall be within the data sheet specifications. ➤ Repeat the measurement for following combinations: <table border="1" data-bbox="613 1487 1370 1771"> <thead> <tr> <th>Ext Ref Frequency</th> <th>Ext Ref Level</th> <th>Ref Output Frequency</th> <th>Ref Out Level Limit</th> </tr> </thead> <tbody> <tr> <td>10 MHz</td> <td>0 dBm</td> <td>10 MHz</td> <td>see data sheet</td> </tr> <tr> <td>10 MHz</td> <td>0 dBm</td> <td>1000 MHz</td> <td>see data sheet</td> </tr> <tr> <td>100 MHz</td> <td>0 dBm</td> <td>100 MHz</td> <td>see data sheet</td> </tr> <tr> <td>100 MHz</td> <td>0 dBm</td> <td>1000 MHz</td> <td>see data sheet</td> </tr> <tr> <td>1000 MHz</td> <td>0 dBm</td> <td>1000 MHz</td> <td>see data sheet</td> </tr> </tbody> </table>	Ext Ref Frequency	Ext Ref Level	Ref Output Frequency	Ref Out Level Limit	10 MHz	0 dBm	10 MHz	see data sheet	10 MHz	0 dBm	1000 MHz	see data sheet	100 MHz	0 dBm	100 MHz	see data sheet	100 MHz	0 dBm	1000 MHz	see data sheet	1000 MHz	0 dBm	1000 MHz	see data sheet
Ext Ref Frequency	Ext Ref Level	Ref Output Frequency	Ref Out Level Limit																						
10 MHz	0 dBm	10 MHz	see data sheet																						
10 MHz	0 dBm	1000 MHz	see data sheet																						
100 MHz	0 dBm	100 MHz	see data sheet																						
100 MHz	0 dBm	1000 MHz	see data sheet																						
1000 MHz	0 dBm	1000 MHz	see data sheet																						

1.4.2 Frequency

1.4.2.1 Frequency Setting

Test method	The frequency setting is tested by running the internal synthesizer adjustments to check the frequency overlap of the VCOs
Measurement	Run: Setup ⇒ Internal Adjustments ⇒ Adjust Synthesis There must be no error message.

1.4.2.2 Setting Time

Test assembly	See section " Test Assembly for Setting Time ", page 11.
Test method	The spectrum analyzer operates as an FM demodulator. A controller transmits the start and the stop frequency via the LAN interface by a special remote command. The DUT trigger connector on the rear panel is programmed as trigger pulse output. The analyzer is triggered by the signal generated on the DUT trigger output. At switch over from start to stop frequency, the settling procedure is displayed on the screen of the analyzer.
Preparation of measurement	<ul style="list-style-type: none"> ➤ Synchronize the reference frequencies of the DUT and the analyzer. ➤ Make LAN and RF connections. ➤ Connect spectrum analyzers trigger connector to DUT trigger output <p>Settings on DUT:</p> <ul style="list-style-type: none"> - :CONNector:TRIGger:OMODE MLATency - Frequency: start frequency unmodulated, - Level Settings/Setting Characteristic: Auto, - Level: 0 dBm, <p>Settings on spectrum analyzer:</p> <ul style="list-style-type: none"> - AMPT/REF LEVEL 0 dBm - FREQ/CENTER/STOP FREQUENCY - FM DEMOD ON - DEMOD BW 100 kHz - RANGE /DEVIATION PER DIV 200 Hz - MEAS TIME 2 ms - TRIGGER EXTERN - External triggering by positive edge at 1.4 V.

Measurement	<ul style="list-style-type: none">➤ Settings on analyzer: - Set the analyzer to the stop frequency➤ Set the DUT to the start frequency f_{start}➤ Send the stop frequency f_{stop} from the controller to the DUT by using the command :TEST:SPEED Stop frequency, Test level<ul style="list-style-type: none">⇒ The externally triggered analyzer displays the settling curve. The setting time is defined as the time required to make the frequency deviation from the stop frequency less than the specified deviation in the data sheet.➤ Switch on IQ-Modulation: I/Q Settings menu: Source Analog Wideband I/Q Input State On and supply 0.5 V DC to the I_{ext} Input Repeat the measurement
-------------	---

Recommended test frequencies and modes	f_{start}	f_{stop}	Mode
		79.9 MHz	6000 MHz
	6000 MHz	79.9 MHz	CW
	93.7 MHz	93.8 MHz	CW, IQ
	93.8 MHz	93.7 MHz	CW, IQ
	187.4 MHz	187.6 MHz	CW, IQ
	187.6 MHz	187.4 MHz	CW, IQ
	374.9 MHz	375.1 MHz	CW, IQ
	375.1 MHz	374.9 MHz	CW, IQ
	749.9 MHz	750.1 MHz	CW, IQ
	750.1 MHz	749.9 MHz	CW, IQ
	1499.9 MHz	1500.1 MHz	CW, IQ
	1500.1 MHz	1499.9 MHz	CW, IQ
	2999.9 MHz	3000.1 MHz	CW, IQ
	3000.1 MHz	2999.9 MHz	CW, IQ
	3000.1 MHz	6000 MHz	CW, IQ
	6000 MHz	3000.1 MHz	CW, IQ
	79.9 MHz	6000.1 MHz	CW
	6000.1 MHz	79.9 MHz	CW
	79.9 MHz	12750 MHz	CW
	12750 MHz	79.9 MHz	CW
	5999.9 MHz	12750 MHz	CW, IQ
	12750 MHz	5999.9 MHz	CW, IQ
	6000.1 MHz	12750 MHz	CW, IQ
	12750 MHz	6000.1 MHz	CW, IQ

Example of Measurement:

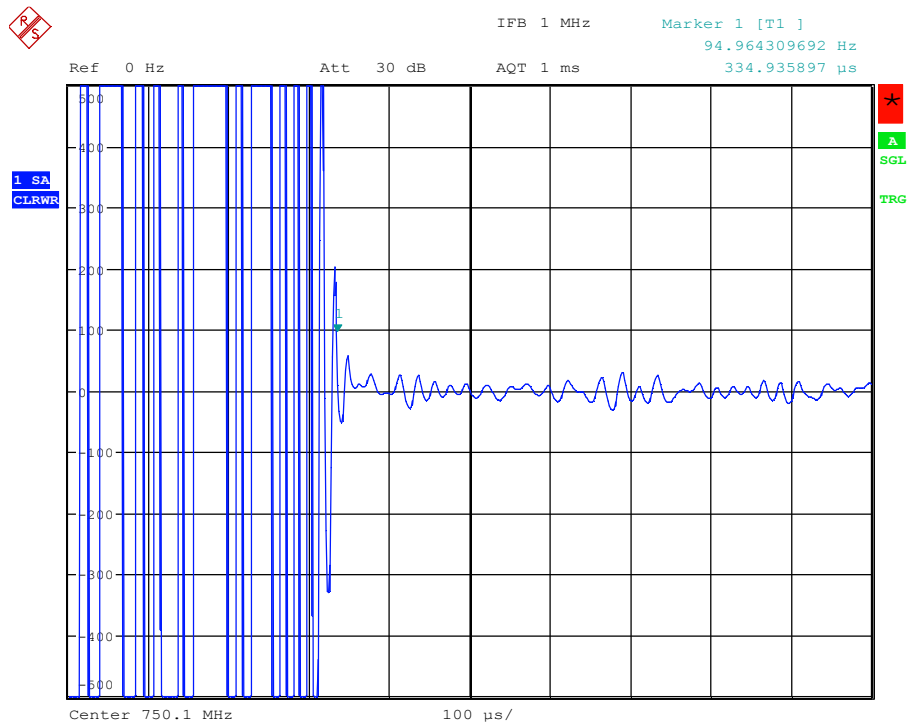

Date: 12.MAR.2012 16:08:54

The marker is set to the time when the trace enters the specified interval of 750.1 MHz ± 150 Hz. The setting time is 335 μs.

1.4.3 Spectral Purity

1.4.3.1 Harmonics

Test equipment	RF analyzer (item 19)
Test setup	<ul style="list-style-type: none"> ➤ Connect the RF analyzer to the RF output of the DUT. ➤ Synchronize the reference frequencies of analyzer and DUT.
Measurement	<p>Settings on analyzer: Reference level = 20 dBm, 10 dB/div. Span 0 Hz, Resolution bandwidth 10 kHz</p> <p>Settings on DUT: - Frequency: test frequencies, unmodulated - Level: test levels</p> <ul style="list-style-type: none"> ➤ First measure the level of the fundamental P_f at the test frequency f as a reference. Then measure the signal levels P_{2rf} and P_{3rf} at twice and three times the carrier frequency f. ⇒ The harmonic spacing is the measured harmonic level referred to the fundamental: $HD2 = P_f - P_{2rf}$ $HD3 = P_f - P_{3rf}$ (in dBc = referred to the carrier)
Recommended test frequencies and levels	<p>Test frequencies: 1 MHz; 5.001 MHz; 10.01 MHz; 20.01 MHz; 40.01 MHz; 60.01 MHz; 80 MHz; 80.01 MHz; 93.75 MHz; 93.76 MHz; 120 MHz; 187.5 MHz; 187.6 MHz; 265 MHz; 375 MHz; 375.1 MHz; 530 MHz; 750 MHz; 750.1 MHz; 1060 MHz; 1500 MHz; 1501 MHz; 2120 MHz; 3000 MHz; 3001 MHz; 3500 MHz; 4000 MHz; 5100 MHz; 6 GHz; 6001 MHz; 6500 MHz; 6501 MHz; 7200 MHz; 7201 MHz; 7300 MHz; 7301 MHz; 8100 MHz; 8900 MHz; 8901 MHz; 9400 MHz; 9401 MHz; 9800 MHz; 10700 MHz; 10701 MHz; 11700 MHz; 12750 MHz</p> <p>Test level: +8 dBm</p> <ul style="list-style-type: none"> ➤ Repeat the measurement with IQ-Modulation switched on: I/Q Settings menu: State On I/Q Wideband Off and supply 0.5 V DC to the I_{ext} Input <p>Test frequencies: 80 MHz; 80.01 MHz; 93.75 MHz; 93.76 MHz; 120 MHz; 187.5 MHz; 187.6 MHz; 265 MHz; 375 MHz; 375.1 MHz; 530 MHz; 750 MHz; 750.1 MHz; 1060 MHz; 1500 MHz; 1501 MHz; 2120 MHz; 3000 MHz; 3001 MHz; 3500 MHz; 4000 MHz; 5100 MHz; 6 GHz; 6001 MHz; 6500 MHz; 6501 MHz; 7200 MHz; 7201 MHz; 7300 MHz; 7301 MHz; 8100 MHz; 8900 MHz; 8901 MHz; 9400 MHz; 9401 MHz; 9800 MHz; 10700 MHz; 10701 MHz; 11700 MHz; 12750 MHz</p> <p>Test level: +8 dBm</p>

1.4.3.2 Subharmonics

Test equipment	RF analyzer (item 19)
Test setup	<ul style="list-style-type: none"> ➤ Connect the spectrum analyzer to the RF output of the DUT. ➤ Synchronize the reference frequencies of analyzer and DUT.
Measurement	<ul style="list-style-type: none"> ➤ First the level of the fundamental is measured as reference, then a signal is searched for at $0.5 \cdot \text{test frequency}$ and $1.5 \cdot \text{test frequency}$. <ul style="list-style-type: none"> ⇒ The subharmonic spacing is the measured level referred to the reference level (dBc = referred to the carrier).
Recommended test frequencies and levels	125 MHz to 12750 MHz in 125 MHz steps level: P_{\min}

1.4.3.3 Nonharmonics

Test equipment	RF analyzer (item 19)
Test setup	<ul style="list-style-type: none"> ➤ Connect the RF analyzer to the RF output of the DUT. ➤ Synchronize the reference frequencies of analyzer and DUT.
Measurement	<p>Setting on DUT Level = 0 dBm</p> <ul style="list-style-type: none"> ➤ First the carrier level P_f is measured at the test frequency f as reference and then the signal level P_{search} is measured at the analyzer search frequency. <ul style="list-style-type: none"> ⇒ The nonharmonic spacing D is the measured level referred to the reference level: $D = P_f - P_{\text{search}}$ (in dBc = referred to the carrier)
	<p>Note: <i>Some of the nonharmonics suppression values to be measured might be outside analyzer specifications. In case of doubt, repeat the measurement with a 3 dB attenuator pad at the analyzer input. If the nonharmonics suppression changes the nonharmonics are due to the analyzer. Because of the bell-shaped noise of the analyzer near the carrier, smaller resolution bandwidths may have to be used. To exclude amplitude independent nonharmonics of the analyzer, use a second generator with different synthesis architecture.</i></p>

Recommended settings and search frequencies:

DUT Frequency	Analyzer search frequency
75 MHz	25 MHz
75 MHz	50 MHz
80 MHz	40 MHz
52.638421053 MHz	$f_c + 130$ kHz
55.562777778 MHz	$f_c + 130$ kHz
58.831176471 MHz	$f_c + 260$ kHz
62.508125000 MHz	$f_c + 260$ kHz
66.675333333 MHz	$f_c + 260$ kHz
71.437857143 MHz	$f_c + 130$ kHz
1000.050000000 MHz	$f_c + 200$ kHz
2000.150000000 MHz	$f_c + 75$ kHz
3000.150000000 MHz	$f_c + 50$ kHz
3000.150000000 MHz	$f_c + 150$ kHz
4000.065000000 MHz	$f_c + 65$ kHz
4017.915178571 MHz	$f_c + 130$ kHz
4056.893522727 MHz	$f_c + 130$ kHz
4400.132000000 MHz	$f_c + 240$ kHz
4419.760714286 MHz	$f_c + 240$ kHz
4454.698181818 MHz	$f_c + 240$ kHz
4480.134400000 MHz	$f_c + 240$ kHz
4500.065000000 MHz	$f_c + 130$ kHz
4613.689090909 MHz	$f_c + 80$ kHz
5091.003636364 MHz	$f_c + 130$ kHz
5142.931428571 MHz	$f_c + 130$ kHz
5250.115500000 MHz	$f_c + 154$ kHz
5409.137272727 MHz	$f_c + 60$ kHz
5625.081250000 MHz	$f_c + 260$ kHz
5920.177600000 MHz	$f_c + 240$ kHz
5946.587142857 MHz	$f_c + 240$ kHz
5966.113636364 MHz	$f_c + 240$ kHz
5999.740000000 MHz	$f_c + 130$ kHz

Repeat the measurement with IQ-Modulation switched on:

I/Q Settings menu:

State On

I/Q Wideband On

and supply 0.5 V DC to the I_{ext} Input

1.4.3.4 Non-systematic nonharmonics

Measurement	<p>Settings on DUT:</p> <p>Test frequencies: 25 MHz, 60 MHz, 100 MHz, 170 MHz, 320 MHz, 560 MHz, 1000 MHz, 1900 MHz, 2900 MHz, 3000 MHz, 4500 MHz, 6000 MHz, 8000 MHz, 10000 MHz, 12750 MHz</p> <p>Test level 0 dBm unmodulated</p> <p>Recommended settings on analyzer:</p> <ul style="list-style-type: none"> - Max peak detector - Filter Type: FFT - Ref-Level 0 dBm <p>➤ Set analyzer center frequency to 1 GHz, span to 40 MHz and resolution bandwidth to 2 kHz</p> <ul style="list-style-type: none"> - Measure carrier level P - all signals other than the carrier must be below specified value <p>➤ Set analyzer span to 100 kHz and resolution bandwidth to 200 Hz</p> <ul style="list-style-type: none"> - all signals other than the carrier must be below specified value <p>➤ Repeat the measurement with IQ-Modulation switched on:</p> <p>I/Q Settings menu:</p> <ul style="list-style-type: none"> State On I/Q Wideband On <p>and supply 0.5 V DC to the I_{ext} Input</p>
	<p>Note: <i>Some of the nonharmonics suppression values to be measured might be outside analyzer specifications. In case of doubt, repeat the measurement with a 3 dB attenuator pad at the analyzer input. If the nonharmonics suppression changes the nonharmonics are due to the analyzer. Because of the bell-shaped noise of the analyzer near the carrier, smaller resolution bandwidths may have to be used. To exclude amplitude independent nonharmonics of the analyzer, use a second generator with different synthesis architecture.</i></p>

1.4.3.5 Wideband Noise

Test equipment	RF analyzer (item 19)
Test setup	<ul style="list-style-type: none"> ➤ Connect the RF analyzer to the RF output of the DUT. ➤ Synchronize the reference frequencies of analyzer and DUT.
Test method	The carrier power is measured first. Then the center frequency of the analyzer is increased by 10 MHz and the noise power in a small bandwidth is measured. The difference of the carrier power and the noise power in 1 Hz bandwidth, which is calculated from the measurement, is defined as wideband noise. Because wideband noise degrades with lower electronic levels at the output step attenuator input, the output level of the generator has to be set to the lowest level before switching the step attenuator.
Measurement	<ul style="list-style-type: none"> ➤ Settings on DUT equipped with Step Attenuator (Option : <ul style="list-style-type: none"> - frequency: test frequency - Level: 12 dBm - determine Att-fixed range upper Level P_{upper}: - \Rightarrow RF \Rightarrow Level \Rightarrow Att fixed range \Rightarrow upper - ATT MODE fixed - set level to $P_{upper} - 7$ dB ➤ Settings on DUT without Step Attenuator (Option : <ul style="list-style-type: none"> - frequency: test frequency - Level: 12 dBm ➤ Settings on analyzer: <ul style="list-style-type: none"> - center: test frequency - reference level DUT Level + 1 dB - Attenuator $D_{min} = \text{DUT Level} - P_{1dBM} + 5$ dB \Rightarrow round to next larger available Attenuation of the analyzer ($P_{1dBM} =$ analyzer P1dB level at test frequency) - span 110 kHz - Detector RMS - Sweep Time Manual 1s - switch on channel power measurement with 100 kHz bandwidth ➤ Determine the channel power with the center frequency of the analyzer set to the test frequency and note it down as P_{ref}. ➤ Increase the analyzer center frequency by 9.9 MHz for carrier frequencies up to 6 GHz and by 29.9 MHz for carrier frequencies > 6 GHz to 12.75 GHz. ➤ Inhibit the switching of the attenuator with AMPT RF ATTEN MANUAL without entering a value so that the input mixer is not overdriven. ➤ Lower the reference level of the analyzer by 20 dB, read the new channel power P_{noise}. ➤ Minimize the output level on the DUT by means of RF OFF, read the channel power P_{res}.

Evaluation	<ul style="list-style-type: none"> ➤ If the power $P_{res} < P_{noise} - 0.41 \text{ dB}$ the inherent noise power of the analyzer can be subtracted: $W_{Noise} = -P_{ref} + 10 * \log_{10}(10^{P_{noise}/10} - 10^{P_{res}/10}) - 50 \text{ dB}$ ➤ If the power $P_{res} > P_{noise} - 0.41 \text{ dB}$ the analyzer resolution is not sufficient for a precise measurement. The true result is in such case certainly more than 10 dB below the measured value. The result then is at least: $W_{Noise} = -P_{ref} + P_{noise} - 50 \text{ dB} - 10 \text{ dB}$ <p>⇒ The difference between the (possibly corrected) power P_{noise} in dBm and the power P_{ref} in dBm is the broadband noise floor in dBc.</p>
Recommended test frequencies	<ul style="list-style-type: none"> ➤ 1 MHz; 5.001 MHz; 10.01 MHz; 20.01 MHz; 40.01 MHz; 60.01 MHz; 80 MHz; 80.01 MHz; 93.75 MHz; 93.76 MHz; 120 MHz; 120.1 MHz; 187.5 MHz; 187.6 MHz; 265 MHz; 375 MHz; 375.1 MHz; 530 MHz; 750 MHz; 750.1 MHz; 1059 MHz; 1500 MHz; 1501 MHz; 2120 MHz; 3000 MHz; 3001 MHz; 3500 MHz; 4000 MHz; 5100 MHz; 6 GHz; 6001 MHz; 6500 MHz; 6501 MHz; 7200 MHz; 7201 MHz; 7300 MHz; 7301 MHz; 8100 MHz; 8900 MHz; 8901 MHz; 9400 MHz; 9401 MHz; 9800 MHz; 10700 MHz; 10701 MHz; 11700 MHz; 12750 MHz ➤ Repeat the measurement with IQ-Modulation switched on: I/Q Settings menu: State On I/Q Wideband On and supply 0.5 V DC to the I_{ext} Input

1.4.3.6 SSB Phase Noise

The SSB phase noise of the DUT can be measured directly if a Phase Noise Test Set is available. An R&S FSUP or any other analyzer with phase noise option is suitable if its own phase noise is at least 6 dB less than the guaranteed DUT Phase noise in the data sheet.

Measurement: Set the Level of the DUT to 0 dBm and measure the phase noise at 20 kHz offset with the analyzer in phase noise mode.

If no suited analyzer is available, the Phase noise can be measured with the aid of a second generator and a mixer:

Test assembly	See section " Test Assembly for SSB Phase Noise and Jitter ", page 10.
Test method	The two generators are set to the test frequency and synchronized with a phase offset of 90° (phase quadrature). Mixing to 0 Hz suppresses the RF carrier. Due to the phase quadrature, the mixer supplies a voltage representing the phase difference between the input signals. This voltage is measured with the spectrum analyzer.

<p>Measurement</p>	<ul style="list-style-type: none"> ➤ Set the levels of the two generators in accordance with the specifications of the mixer used. (For the MITEQ-DB0118 mixer set the LO-level to +10 dBm and the RF-level to 0 dBm.) ➤ Settings of the DUT: <ul style="list-style-type: none"> - PM int - PM deviation 0.01 rad - Modulation frequency 19 kHz ➤ Settings on the analyzer: <ul style="list-style-type: none"> - Center frequency 19.5 kHz - Span 2 kHz - Input coupling DC - Attenuator manual 0 dB - average on, count = 10 - average mode: linear/ power - Filter Type: FFT - Resolution Bandwidth 10 Hz - set marker to 19 kHz. - set delta marker to 20 kHz ➤ Adjust the phase of the DUT for phase quadrature: Set the Delta Phase in the Frequency/Phase menu for maximum marker readout at 19 kHz in the Delta Phase range of 0° to 180°. Note down the relative Delta marker level D. ➤ Calculate the SSB phase noise in dbc/Hz: <ul style="list-style-type: none"> - The Delta Marker measures the noise in 10 Hz bandwidth. The power in 1 Hz bandwidth is one tenth of this power: $\log_{10}(10)$ - The PM with a modulation rate of 0.01 rad is equivalent to a phase noise readout of -46 dBc. - The phase noises of the two generators add together: - 3 dB if they are of the same type. <p>If the reference generator is of the same type as the DUT: $PN = D - 10 * \log_{10}(10) - 46 \text{ dB} - 3 \text{ dB}$ PN = D - 59 dB</p> <p>If the phase noise of the reference generator is at least 10 dB better than the phase noise of the DUT: $PN = D - \log_{10}(10) - 46 \text{ dB}$ PN = D - 56 dB</p>
<p>Recommended test frequencies</p>	<ul style="list-style-type: none"> ➤ 1 GHz, 2 GHz, 4 GHz, 6 GHz, 8 GHz, 10 GHz, 12 GHz ➤ Repeat the measurement with IQ-Modulation switched on: I/Q Settings menu: <ul style="list-style-type: none"> State On I/Q Wideband On and supply 0.5 V DC to the I_{ext} Input

Example: Two instruments measured against each other

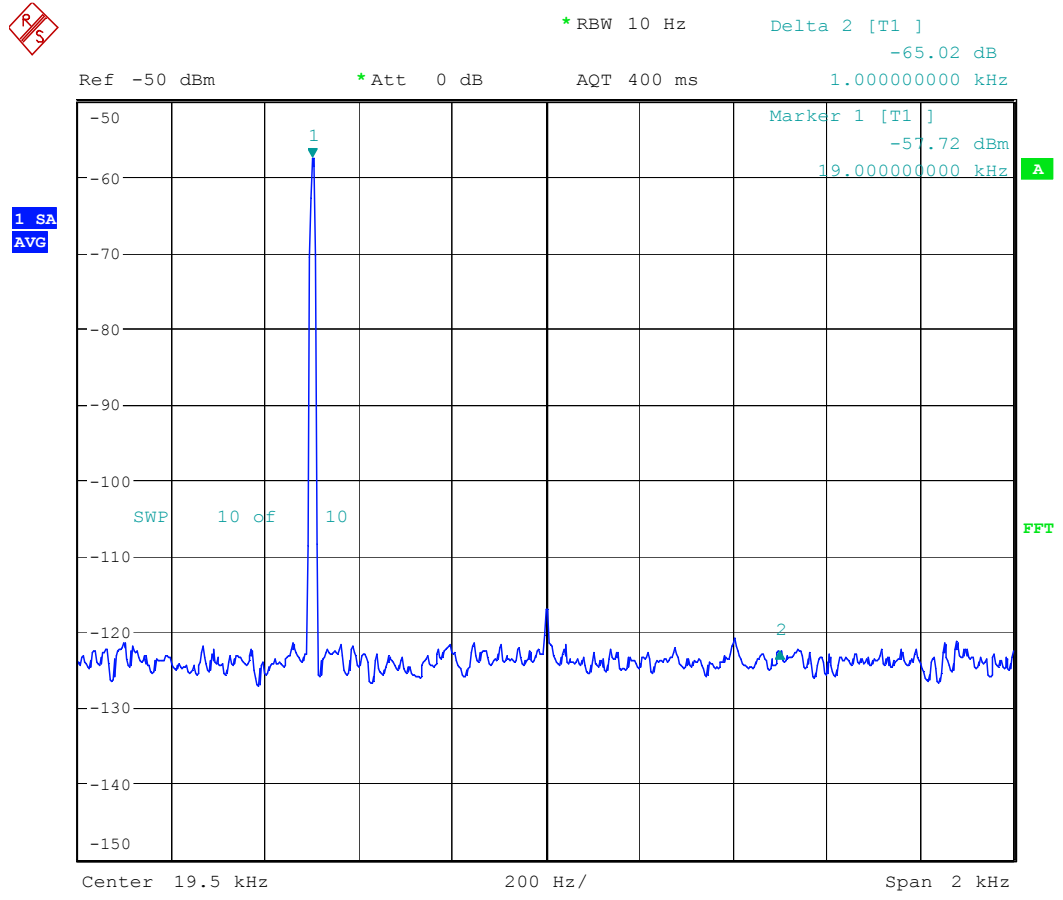

Date: 22.FEB.2008 16:32:46

$$PN = -65.02 \text{ dBc} - 65 \text{ dB} = 130.02 \text{ dBc/ Hz}$$

1.4.3.7 Residual FM

Test assembly	Connect RF analyzer to RF socket of the DUT.
Test method	<p>The FM demodulator of the analyzer is used to FM-demodulate the CW signal of the DUT. By setting the AF-low-pass and high-pass-filters the RMS value in the desired bandwidth can be measured. The value displayed is the sum of the analyzer residual FM and the DUT residual FM. Because both components are uncorrelated, the displayed result is worse than residual RMS of the DUT alone. Therefore, if the sum is in tolerance according to the data sheet the DUT is also in tolerance.</p>
Measurement	<ul style="list-style-type: none"> ➤ Settings on DUT: <ul style="list-style-type: none"> - frequency: 1 GHz - Level: 0 dBm ➤ Settings on analyzer: <ul style="list-style-type: none"> - CENTER: 1 GHz - REFERENCE LEVEL: 1 dBm - FM DEMOD - FM DEMOD ⇒ MEAS TIME: 100 ms - FM DEMOD ⇒ DEMOD BW: 200 kHz - FM DEMOD ⇒ AF-FILTER ⇒ HIGH PASS AF FILTER: 300 Hz - FM DEMOD ⇒ AF-FILTER ⇒ LOW PASS AF FILTER: 3 kHz ➤ The Residual FM in the frequency range 300 Hz – 3 kHz is the RMS value displayed. ➤ Repeat the measurement with setting the HIGH PASS AF FILTER: to 20 Hz and the LOW PASS AF FILTER to 23 kHz.

Example:



IFB 2 MHz

Ref 0 Hz

Att 30 dB

AQT 50 ms

1 AP
CLRWR

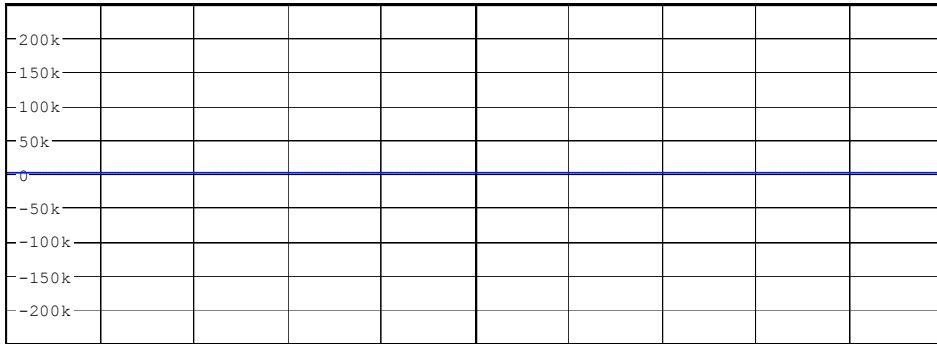

Center 1 GHz

5 ms/

Frequency Modulation Summary

Coupling	DC	Carrier Offset	45.639 Hz
Deviation	+peak 12.93 Hz	Carrier Power	-0.91 dBm
	-peak -12.41 Hz	Modulation Frequency	--- Hz
	+peak/2 12.67 Hz	Sampling Rate	250 kHz
	RMS 3.465 Hz	Record Length	12501
		Demod Bandwidth	200 kHz
		AF Filter	HP 20 Hz
			LP 23 kHz

Date: 22.FEB.2008 17:35:25

Residual FM = 3.465 Hz

1.4.3.8 Residual AM

Test assembly	Connect RF analyzer to RF socket of the DUT.
Test method	The FM demodulator of the analyzer is used to AM-demodulate the CW signal of the DUT. By setting the AF-low-pass and high-pass-filters the RMS value in the desired bandwidth can be measured. The value displayed is the sum of the analyzer residual AM and the DUT residual AM. Because they are uncorrelated, the displayed result is worse than residual RMS of the DUT alone. Therefore, if the sum is in tolerance according to the data sheet the DUT is also in tolerance.
Measurement	<ul style="list-style-type: none"> ➤ Settings on DUT: <ul style="list-style-type: none"> - frequency: 1 GHz - Level: 0 dBm ➤ Settings on analyzer: <ul style="list-style-type: none"> - CENTER: 1 GHz - REFERENCE LEVEL: 1 dBm - AMPT ⇨ RF ATTEN MANUAL: 10 dB - FM DEMOD - FM DEMOD ⇨ RESULT DISPLAY ⇨ AM - FM DEMOD ⇨ MEAS TIME: 100 ms - FM DEMOD ⇨ DEMOD BW: 200 kHz - FM DEMOD ⇨ AF-FILTER ⇨ HIGH PASS AF FILTER: 20 Hz - FM DEMOD ⇨ AF-FILTER ⇨ LOW PASS AF FILTER: 20 kHz ➤ The Residual AM in the frequency range 20 Hz – 23 kHz is the RMS value displayed.
Test frequencies	5 MHz, 450 MHz, 1 GHz, 2.2 GHz, 3.2 GHz, 4.5 GHz, 6 GHz, 8 GHz, 10 GHz, 12.75 GHz

Example:



IFB 2 MHz

Ref 0 % * Att 5 dB AQT 200 ms

1 AP
CLRWR

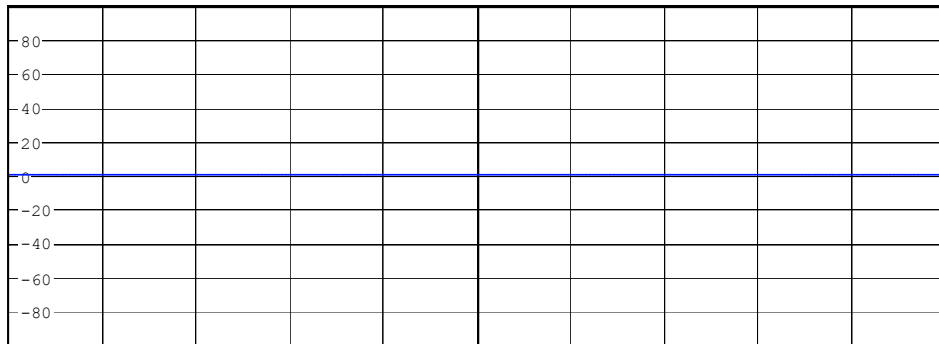

Center 1 GHz 20 ms/

Amplitude Modulation Summary

Modulation Depth	0.022 %	Carrier Power	-0.87 dBm
Modulation +peak	0.022 %	Modulation Frequency	--- Hz
-peak	-0.023 %	Sampling Rate	250 kHz
+peak/2	0.022 %	Record Length	50001
RMS	0.005 %	Demod Bandwidth	200 kHz
		AF Filter	HP 20 Hz
			LP 23 kHz

Date: 25.FEB.2008 16:33:44

Residual AM = 0.005 %

1.4.4 Level Data

1.4.4.1 Level Uncertainty

Test method	The level uncertainty is measured in two steps. First, the frequency response is measured at a fixed level with high frequency resolution. Then the level dependant uncertainty is measured at fixed frequencies over the specified range.
Test equipment	<ul style="list-style-type: none"> - RF power meter (item 8) - RF analyzer (item 19) - Low-noise preamplifier (item 9)

Test method for levels in measurement range of power meter

Test setup	Connect power meter to RF output socket.
Measurement	<ul style="list-style-type: none"> ➤ Setting on DUT: <ul style="list-style-type: none"> - Levels : test level - Level Settings⇒Setting Characteristic: Auto <p>Measure the level P_{absolute} at the recommended test frequencies up to RF_{max}.</p> <p>⇒ The level error is the deviation of the measured level from the set value.</p> <ul style="list-style-type: none"> ➤ Repeat the measurement with IQ-Modulation switched on: I/Q Settings menu: State On I/Q Wideband On and supply 0.5 V DC to the I_{ext} Input <p>Use test frequencies according to the recommended test frequency set starting at 80 MHz up to RF_{max}</p>
Recommended test levels for frequency response measurement	<ul style="list-style-type: none"> ➤ ALC Mode AUTO Option : +15 dBm Without Option : +15 dBm; 0 dBm
Recommended test frequencies for the level frequency response measurement	CW mode: 1 MHz; 5 MHz to 75 MHz in 10 MHz steps; 80 MHz; CW and IQ mode: 80.01 MHz; 87.5 MHz to 12.75 GHz in 25 MHz Steps
Measurement of level dependent uncertainty for instruments with no step attenuator (w/o R&S SGS-B26)	
Recommended test levels	0 dBm to 15 dBm in 3 dB steps
Recommended test frequencies.	1 MHz; 80 MHz; 80,01 MHz; 487.5 MHz; 1087.5 MHz, 2187.5 MHz, 3187.5 MHz, 4012.5 MHz, 5012.5 MHz, 5987.5 MHz, 7012.5 MHz, 8012.5 MHz, 9012.5 MHz, 10012.5 MHz, 11012.5 MHz, 12012.5 MHz, 12737.5 MHz

Test method for low levels

Test principle	<p>Low levels can only be measured using a frequency selective measurement instrument. Spectrum analyzers with digital IF are best suited for this measurement due to their low linearity error. The absolute accuracy of these analyzers is not sufficient for this measurement. So a relative measurement referred to the measurements performed with the power meter is used to increase the accuracy of the measurement.</p> <p>Only by switching the input attenuator and preamplifier (when available) of the analyzer the needed dynamic range of more than 120 dB can be reached. After switching the analyzer attenuator or preamplifier, a continuity calibration is to be carried out. It is therefore recommended to switch the attenuator not until reaching 50 dB under full scale, since the linearity errors are very small in this range.</p>
Test setup	<ul style="list-style-type: none"> ➤ Connect the spectrum analyzer to the RF output of the DUT with precision RF measurement cables.
Measurement	<ul style="list-style-type: none"> ➤ Settings on DUT <ul style="list-style-type: none"> Frequency recommended test frequencies Level +15 dBm, unmodulated ➤ Setting on the analyzer <ul style="list-style-type: none"> Test frequency SPAN 10 Hz FILTER TYPE FFT RES BW 5 Hz set Marker to test frequency Reference level $P_{ref} = +17$ dBm ➤ Read the marker level P_{Marker} and calculate the correction factor $C = P_{absolute} - P_{Marker}$ with $P_{absolute}$ from the measurements performed with the power meter. ➤ Now decrease the DUT level in 5 dB steps and calculate the output power P by adding the Correction factor C to the marker readout. ➤ As soon as the marker level P_{Att1} is lower than $P_{ref} - 45$ dB increase the sensitivity of the analyzer by reducing the input attenuation, switching on the internal preamplifier if available and reducing the resolution bandwidth to 1 Hz for levels below -90 dBm. Set the analyzer reference level to $P_{Att1} + 1$ dB. After switching the analyzer sensitivity read out the marker level P_{Att2} and recalculate the Correction factor: $C_{new} = C_{old} + P_{Att1} - P_{Att2}$ ➤ Instruments equipped with Option R&S SGS-B26: <ul style="list-style-type: none"> Continue the measurement down to -120 dBm in 5 dB steps. Instruments without Option R&S SGS-B26: <ul style="list-style-type: none"> Continue the measurement down to 0 dBm in 5 dB steps.
Recommended test frequencies.	1.02 MHz, 77.5 MHz, 512.5 MHz, 1087.5 MHz, 2187.5 MHz, 3187.5 MHz, 4012.5 MHz, 5012.5 MHz, 5987.5 MHz, 7012.5 MHz, 8012.5 MHz, 9012.5 MHz, 10012.5 MHz, 11012.5 MHz, 12012.5 MHz, 12737.5 MHz

1.4.4.2 Output Impedance

Test assembly	See section " Test Assembly for Output Impedance (VSWR) ", page 11.
Test method	For the VSWR measurement of a source the effect of the level control must be taken into account. For this purpose, an auxiliary generator is used which transmits a wave with a slightly offset carrier frequency into the DUT. The difference frequency has to be within the control bandwidth of the level control. In the case of ideal source impedance, the wave from the auxiliary generator is not reflected by the DUT. In the case of not ideal DUT source impedance, the output wave of the DUT and the reflected wave of the auxiliary generator are superimposed on one another. A directional coupler couples a part of these outgoing superimposed waves to an analyzer. The frequency offset, results in a beat of the superimposed outgoing waves. The VSWR is the ratio between the maximum and minimum amplitude of the beat.
Measurement	<ul style="list-style-type: none"> ➤ Settings on DUT: <ul style="list-style-type: none"> - Level: test level - Frequency: test frequency, unmodulated - Increase the level control bandwidth using the command CALibration:LEVel:BWIDth HIGH ➤ Settings on spectrum analyzer: <ul style="list-style-type: none"> - Test frequency, span 0 Hz, test level - Resolution and video bandwidth 10 kHz - Linear level scale - Sweep time 20 ms ➤ Settings on second signal generator: <ul style="list-style-type: none"> - set the frequency to the test frequency – 100 Hz, - set minimum level, unmodulated. ➤ Vary the reference level to bring the line displayed on the screen of the spectrum analyzer approximately into the middle of the screen. Measure the voltage of the signal V_{ref}. ➤ Unscrew the VSWR bridge from the DUT and let the test port open. Increase the level of the second signal generator until the voltage on the analyzer is $V_{ref} \pm 0.5 \%$. ➤ Screw the VSWR bridge onto the DUT again. ➤ Measure the maximum voltage V_{max} and minimum voltage V_{min} of the sinusoidal trace. Calculate the VSWR: $VSWR = V_{max}/V_{min}$
Recommended test frequencies and levels	<ul style="list-style-type: none"> ➤ Test frequencies: from 1 MHz every 50 MHz up to RF_{max}. ➤ Test levels for instruments equipped with Option R&S SGS-B26: first the (frequency dependent) switching level of the first step attenuator has to be determined). 3 dB above is the first measurement level. Then the first five attenuator steps are measured by reducing the level in steps of 6 dB. This way all possible output impedances are recorded. Test level for instruments without Option R&S SGS-B26: 0 dBm

1.4.4.3 Setting Time

Test assembly	See section " Test Assembly for Setting Time ", page 11.
Test method	The RF analyzer is operated as a fast level meter in zero span. A controller transmits the start and the stop level via the LAN interface by a special remote command. The DUT trigger connector on the rear panel is programmed as trigger pulse output. The analyzer is triggered by the signal generated on the DUT trigger output. At switch over from start to stop level, the settling procedure is displayed on the screen of the analyzer.
Preparation of measurement	<ul style="list-style-type: none"> ➤ Synchronize the reference frequencies of the DUT and the analyzer. ➤ Make LAN interface and RF connections. ➤ Connect the spectrum analyzer trigger input to the DUT trigger output ➤ Setting on DUT: <ul style="list-style-type: none"> - :CONNector:TRIGger:OMODE MLATency - Frequency: test frequency - Level: start level ➤ Settings on spectrum analyzer: <ul style="list-style-type: none"> - REFERENCE LEVEL: target level + 3 dB - AMPLITUDE LOG RANGE 10 dB - RESOLUTION BANDWIDTH 200 kHz - VIDEO BANDWIDTH 2 MHz - SPAN 0 Hz - SWEEP TIME: 1 s / 2 ms - TRIGGER EXTERN - External triggering by positive edge at 1.4 V.
Measurement	<ul style="list-style-type: none"> ➤ Send the stop level from the controller to the DUT by using the command :TEST:SPEED Test frequency, Stop level. ⇒ The externally triggered analyzer displays the settling curve. The setting time is defined as the time from which on the level deviation from the final level (1 second after switch over) is less than the specified deviation in the data sheet. ➤ Measure the following steps with Level Characteristic: Auto (ALC state Table&On) ➤ Measure the following steps with ALC state On ➤ Measure the following steps with IQ-Modulation switched on: I/Q Settings menu: State On I/Q Wideband On, ALC state Table&On and supply 0.5 V DC to the I_{ext} Input

Recommended test frequencies and levels

Frequencies: 1 MHz, 30 MHz, 375 MHz, 1.1 GHz, 2.2 GHz, 3.2 GHz, 6 GHz, 7.5 GHz, 10 GHz, 12.75 GHz

Start level	Stop level	Remark
-10 dBm	15 dBm	
15 dBm	-10 dBm	
-120 dBm	+15 dBm	Only for instruments equipped with option R&S SGS-B26
-35 dBm	-5 dBm	

1.4.5 I/Q modulation

1.4.5.1 Input Impedance (VSWR)

Test equipment	See section " Test Assembly for Output Impedance (VSWR) ", page 11.
Test method	Same as for the output impedance of the DUT.
Test setup	Connect the test port of the VSWR bridge to the I or Q input instead of the RF output.
Measurement	<ul style="list-style-type: none"> ➤ Settings on DUT: Frequency 900 MHz RF on Level 0 dBm (PEP) I/Q Settings menu: State On I/Q Wideband On, ➤ Settings on signal generator: - Level: 10 dBm - Frequency: test frequencies <p>Let the measuring port of the VSWR bridge unconnected and measure the level P_{ref} as reference level. Connect the VSWR bridge to the I input and measure the level P_I. Calculate the VSWR:</p> $VSWR = \frac{1 + \sqrt{P_I / P_{ref}}}{1 - \sqrt{P_I / P_{ref}}}$ <p>Repeat the measurement for the Q input.</p>
Recommended test frequencies	1 MHz, 10 MHz, 20 MHz, 40 MHz, 60 MHz, 80 MHz, 100 MHz, 150 MHz to 500 MHz in steps of 50 MHz

1.4.5.2 Error Vector

Test assembly	See section " Test Assembly for I/Q Modulation ", page 12.
Measurement	<p>Instead of a static measurement, an equivalent dynamic measurement with a low symbol rate is carried out.</p> <ul style="list-style-type: none"> ➤ Settings on DUT: <ul style="list-style-type: none"> RF On Level 0 dBm (PEP) I/Q Settings menu: <ul style="list-style-type: none"> State On I/Q Wideband Off ➤ Generate a modulation signal on the ARB generator using the controller and the simulation program: <ul style="list-style-type: none"> - Modulation 16QAM - No coding - SQR COS filter with $\alpha = 0.5$ - PRBS-9 data sequence - Pulse width and over sampling 32 - Length 100 symbols - Symbol clock 10 kHz ➤ Check if the channels on the ARB generator are equal and adjust if necessary. ➤ Make the corresponding settings on the demodulator. Result length 80 symbols. ➤ Measure the error vector magnitude (peak and rms) at the recommended test frequencies.
Recommended test frequencies	80.01 MHz, 250 MHz to 12.75 GHz in steps of 500 MHz

1.4.5.3 Residual Carrier and Leakage

Test equipment	RF analyzer (item 19)
Test setup	<ul style="list-style-type: none"> ➤ Connect the RF analyzer to the RF output of the DUT.
Measurement	<ul style="list-style-type: none"> ➤ Settings on DUT: <ul style="list-style-type: none"> RF On Frequency test frequency Level 0 dBm Level menu: <ul style="list-style-type: none"> ALC State Off(Table) I/Q Settings menu: <ul style="list-style-type: none"> State Off I/Q Wideband Off ➤ Settings on analyzer: <ul style="list-style-type: none"> FREQ/CENTER = test frequency, SPAN 1 MHz, AMPT/REF LEVEL = test level ➤ First measure the unmodulated level P_{ref} as a reference. ➤ Then switch on I/Q modulation with 50 Ohm terminated I- and Q-inputs (I/Q Settings menu: State On) and measure the residual carrier level $P_{carrier}$. <ul style="list-style-type: none"> ⇒ The carrier suppression in dBc is: <ul style="list-style-type: none"> $D_{carrier} = P_{ref} - P_{carrier}$ in dBc = referred to the carrier. ➤ Set Impairments State to On and Leakage to 2 % on the DUT. Starting from 100 MHz and then every 100 MHz measure the residual carrier. <ul style="list-style-type: none"> ⇒ The residual carrier should increase to 2 % (-34 dBc).
Recommended test frequencies	12.5 MHz to 12737.5 MHz in 25 MHz steps

1.4.5.4 I/Q Imbalance

Measurement of imbalance	
Test equipment	<ul style="list-style-type: none"> - RF analyzer (item 19) - Arbitrary waveform generator (item 14)
Test setup	<ul style="list-style-type: none"> ➤ Connect the spectrum analyzer to the RF output of the DUT. ➤ Connect the Arbitrary waveform generator to the DUT baseband input.
Measurement	<ul style="list-style-type: none"> ➤ Settings on DUT: <ul style="list-style-type: none"> RF On Frequency 900 MHz Level 0 dBm (PEP) Level menu: <ul style="list-style-type: none"> ALC State Off(Table) I/Q Settings menu: <ul style="list-style-type: none"> State On I/Q Wideband Off Impairments State on Imbalance 1.0 dB ➤ Settings on analyzer: <ul style="list-style-type: none"> - Center frequency = test frequency, span 1 MHz - Reference level = test level +3 dB - Scale 1 dB/div ➤ Apply a DC voltage of 0.5 V to the I-input and 0 V to the Q-input. Measure the output level P_I. Then apply a DC voltage of 0.5 V to the Q-input and 0 V to the I-input. Measure the level P_Q. The Imbalance is: Imbalance = $P_I - P_Q$

1.4.5.5 Adjacent Channel Power for 3GPP FDD

Test equipment	RF analyzer (item 19) Arbitrary waveform generator (item 14) Lowpass filter (item 21)
Test setup	<ul style="list-style-type: none"> ➤ Connect the IQ-modulation source to the Lowpass filter inputs. ➤ Connect the Lowpass filter outputs to the I/Q-inputs of the DUT. ➤ Connect RF analyzer to RF output of DUT.
Test method	<ul style="list-style-type: none"> ➤ Set standard 3GPP FDD Test Model 1-64 in the modulation source baseband and feed the I/Q signal into the DUT I/Q-inputs. Perform the measurements with the 3GPP measurement setting of the R&S FSQ. Use lowpass filtering of the I/Q signals to avoid degradation of the ACPR measurement by baseband generator noise.
Measurement	<ul style="list-style-type: none"> ➤ Settings on DUT <ul style="list-style-type: none"> Level: 10 dBm (PEP) Frequency: Test frequency I/Q Settings menu: <ul style="list-style-type: none"> State On I/Q Wideband Off ➤ Settings on DUT or signal generator <ul style="list-style-type: none"> 3GPP FDD: <ul style="list-style-type: none"> Test Setups Test_Model_1_64channels State ON ➤ Settings on analyzer <ul style="list-style-type: none"> FREQ CENTER: 2160 MHz MEAS → CHAN PWR ACP <ul style="list-style-type: none"> → CP /ACP STANDARD WCDMA 3GPP FWD → SWEEP TIME 1 sec → NOISE CORR ON → ADJUST REF LVL ➤ Measure ACP: <ul style="list-style-type: none"> Read out Adjacent Channel and Alternate Channel (take the larger of the two measurement values UPPER/LOWER)
Recommended test frequencies	1800 MHz, 2000 MHz, 2200 MHz

1.4.5.6 Frequency Response of Baseband Bypass path

Test equipment	<ul style="list-style-type: none"> - RF Power meter (item 8) - Signal generator (item 5)
Test setup	<ul style="list-style-type: none"> ➤ Connect the RF output of the DUT to the power meter and connect the signal generator to the I input of the DUT.
Test method	<p>In the Baseband Bypass mode, the DUT operates like a controllable gain amplifier with I and Q as input connectors and RF OUT as output connector.</p> <p>By applying a sinewave AC voltage of variable frequency to the I (or Q) input and measuring the RF OUT level, the frequency response can be determined.</p>
Measurement	<ul style="list-style-type: none"> ➤ Settings on DUT: RF On :SOURce:OPMode BBBYpass Level 10 dBm (PEP) ATT MODE fixed ➤ Setting on signal generator: Level 4 dBm corresponding to 0.5 V (Vpeak) ➤ Measure the level at RF OUT at the recommended test frequencies <ul style="list-style-type: none"> ⇒ The modulation frequency response is the difference between the highest and the lowest measured sideband level.
Recommended test frequencies	1 MHz, from 10 MHz to 150 MHz in steps of 10 MHz

1.4.5.7 Level linearity of Baseband Bypass path

Test equipment	<ul style="list-style-type: none"> - RF analyzer (item 19) - Signal generator (item 5)
Test setup	<ul style="list-style-type: none"> ➤ Connect the RF output of the DUT to the power meter, and connect the signal generator to the I input of the DUT.
Test method	<p>In the Baseband Bypass mode, the DUT operates like a controllable gain amplifier with I and Q as input connectors and RF OUT as output connector.</p> <p>By applying signal to the I (or Q) input, varying the DUT level setting and measuring the RF OUT level, the level linearity can be determined.</p>
Measurement	<ul style="list-style-type: none"> ➤ Settings on DUT: RF On :SOURce:OPMode BBBYpass Level Test level ATT MODE fixed ➤ Setting on signal generator: Level 4 dBm corresponding to 0.5 V (Vpeak) Frequency: Test frequency ➤ Setting on the analyzer Test frequency Reference level = 25 dBm SPAN 10 Hz FILTER TYPE FFT RES BW 5 Hz set Marker to test frequency ➤ Read the marker level P_{ref} ➤ At all test levels, read the marker level P_{Marker} and calculate the level error referred to P_{ref}.
Recommended test frequencies	1 MHz, 20 MHz, 80 MHz
Recommended test levels	<p>Test levels for instruments equipped with Option R&S SGS-B26: Set level to 0 dBm and determine P_{max}. Use test levels from P_{max} down to $P_{max} - 20$ dB in steps of 1 dB.</p> <p>Test level for instruments without Option R&S SGS-B26: 15 dBm down to -5 dBm in steps of 1 dB</p>

1.4.6 Phase Coherence Levels (Option R&S SGS-K90)

Test assembly	The second Signal generator (item 5) is connected to the LO IN-connector and the RF power meter (item 8) is connected to LO OUT-connector.
Test method	A LO-Signal from the second signal generator is fed into the LO input. With LO-Coupling set to external and the LO-output switched on the power at the LO-out SMA-connector is measured with the power meter.
Measurement	<ul style="list-style-type: none"> ➤ Settings on DUT: <ul style="list-style-type: none"> RF: State ON Level: -30 dBm Frequency: recommended test frequencies or RF_{max}, whichever is lower Frequency/Phase menu: <ul style="list-style-type: none"> LO Coupling ⇨ Source Ext LO Coupling ⇨ REF/LO Output LO ➤ Setting on second signal generator: <ul style="list-style-type: none"> - Level: + 7 dBm / + 13 dBm - Frequency: recommended test frequencies - RF: State ON ➤ Set the frequency of the second generator to the recommended test frequencies. Set the level of the second signal generator to +7 dBm and measure the level $P_{+7\text{ dBm}}$. Set the level of the second signal generator to +13 dBm and measure the level $P_{+13\text{ dBm}}$ <ul style="list-style-type: none"> ⇨ The level $P_{+7\text{ dBm}}$ and $P_{+13\text{ dBm}}$ should be $+10\text{ dBm} \pm 3\text{ dB}$ ⇨ The level difference between $P_{+13\text{ dBm}}$ and $P_{+7\text{ dBm}}$ should be less than $\pm 1\text{ dB}$
Recommended test frequencies	80.01 MHz, from 150 MHz every 100 MHz up to 6.5 GHz

1.4.7 PCI Express Interface

Test equipment	<ul style="list-style-type: none"> - PCIe test port (item 24) - PCIe cable (item 23)
Test assembly	External device with PCI express Interface is connected to R&S SGS100A PCI express connector
Measurement	<ul style="list-style-type: none"> ➤ Check if external PCI express device can be identified by R&S SGS100A

2 Adjustment

Preliminary Remark

Setting a defined initial state by performing the **PRESET** operation prior to adjustments is recommended. In addition, a valid reference frequency is required, either by setting the instrument to internal reference or by applying an appropriate external reference signal. To ensure that the internal adjustments are valid at operating temperature, at least **30 minutes warm-up time** at this temperature must be observed.

2.1 Procedures after Module Replacement

This chapter describes the necessary measures to restore the performance of the R&S SGS100A after module replacement.

There are no manual adjustments to be performed. Internal adjustment routines are implemented for this purpose. In case external adjustment is required, contact your local Rohde & Schwarz representative.

All spare part boards are tested at Rohde & Schwarz with calibrated working standards according to the performance test. All measurement values are within the specified values including the measurement uncertainty as a minimum guard band.

After replacing an assembly, check the following table to see which service procedure is required.

Changed module	Required action/adjustment/correction	Recommended Test Procedure (refer to chapter 1 " <i>Performance Test</i> ").
Controller Board	SIM card transfer Restore Ethernet MAC Address (see chapter 2.1.1) Perform Factory Preset (sets instrument default hostname) FW update Setup/Internal Adjustments/Adjust All	Instrument Selftest
RF Mainboard	Setup/Internal Adjustments/Adjust All Absolute Level Correction (external)* Attenuator Correction (external)* Attenuator Switchover Correction (external)*	Instrument Selftest Level uncertainty Reference Frequency / Internal Reference mode (for instruments without option R&S SGS-B1)
Doubler Board	Setup/Internal Adjustments/Adjust All Absolute Level Correction (external)* Attenuator Correction (external)* Attenuator Switchover Correction (external)*	Instrument Selftest Level uncertainty
Step Attenuator	Setup/Internal Adjustments/Adjust All Absolute Level Correction (external)* Attenuator Correction (external)*	Instrument Selftest Level uncertainty

Changed module	Required action/adjustment/correction	Recommended Test Procedure (refer to chapter 1 " <i>Performance Test</i> ").
OCXO	Setup/Internal Adjustments/Adjust All	Instrument Selftest Reference Frequency / Internal Reference mode
Power Supply	Setup/Internal Adjustments/Adjust All	Instrument Selftest
Fan	None	Functional Test
Front panel unit	None	Keyboard Test (see chapter 3.2.3) Functional Test
Cables W100, W100A, W110A	Setup/Internal Adjustments/Adjust All Absolute Level Correction (external)* Attenuator Correction (external)*	Level uncertainty

* In case external adjustment is required, contact your local Rohde & Schwarz representative.

2.1.1 Restore Ethernet MAC Address

Each SGS100A has a unique, fixed MAC Address to allow the identification in a Ethernet network. The MAC Address is assigned during the instrument production process and must not be changed afterwards.

The SGS100A utilizes the MAC Address that is stored on the Controller Board. A backup of the MAC Address number is stored on the SIM Card. When replacing a Controller Board, the SIM Card has to be transferred to the new Controller Board and the MAC Address number has to be copied from the SIM Card to the new Controller Board using the following procedure:

- Connect the DUT to a PC via USB. Avoid using a LAN connection, because the instrument hostname has changed after replacing the Controller Board. In addition, the network IP-Address may change after the reboot step, if it is set to Auto (DHCP).
- Start the instrument and open a remote control connection.
- Send the command: DIAGnostic:PRODuCt:MACaddress:REStore SIM
- Reboot the DUT and connect with SGMA GUI
- Check the MAC Address under Setup -> Network Settings...
- Compare the MAC-Address to the 12 digit hex number printed on the label on the bottom side of the DUT.

2.2 Adding Hardware Options

This chapter describes the necessary measures to obtain the extended performance of the R&S SGS100A after installing an additional Hardware Option.

Following Hardware Modules are available:

- R&S SGS-B1 OCXO
- R&S SGS-B26 Step Attenuator
- R&S SGS-B112 Frequency extension CW 12.75 GHz
Only fits to instruments equipped with R&S SGS-B106.
- R&S SGS-B112V Frequency extension IQ 12.75 GHz
Only fits to instruments equipped with R&S SGS-B106V with RF mainboard revision number greater or equal to 6.09.

Note: Instruments with serial numbers lower than 101600 can not be upgraded with the R&S SGS-B112V option due to the installed RF mainboard version.

First install the respective Hardware modules according to the step by step instruction given in chapter 3.

When the hardware installation is fully completed, switch on the instrument and check the detection of the added modules.

- Setup Menu

- Hardware Config... Now the available Hardware is displayed.

To activate the Hardware Option, the appropriate Hardware Option Key must be installed on the instrument SIM Card.

- Setup Menu

- Install Option...

- Option Key: Type the Option Key Number delivered with your HW Option

Restart the instrument and perform the adjustments and tests according to the following table.

Installed module	Required action/adjustment/correction	Recommended Test Procedure (refer to chapter 1 "Performance Test").
OCXO	Setup/Internal Adjustments/Adjust All	Instrument Selftest Reference Frequency / Internal Reference mode
Doubler Option SGS-B112 or SGS-B112V (instrument without Step Attenuator Option SGS-B26)	Setup/Internal Adjustments/Adjust All Absolute Level Correction (external)*	Full Performance Test
Doubler Option SGS-B112 or SGS-B112V (instrument with Step Attenuator Option SGS-B26)	Setup/Internal Adjustments/Adjust All Absolute Level Correction (external)* Attenuator Correction (external)* Attenuator Switchover Correction (external)*	Full performance Test

Internal Adjustments

Installed module	Required action/adjustment/correction	Recommended Test Procedure (refer to chapter 1 " Performance Test ").
Step Attenuator Option SGS-B26 (instrument without Doubler Option SGS-B112 or SGS-B112V)	Setup/Internal Adjustments/Adjust All Absolute Level Correction (external)* Attenuator Correction (external)*	Full performance Test
Step Attenuator Option SGS-B26 (instrument with Doubler Option SGS-B112 or SGS-B112V)	Setup/Internal Adjustments/Adjust All Absolute Level Correction (external)* Attenuator Correction (external)* Attenuator Switchover Correction (external)*	Full performance Test

* In case external adjustment is required, contact your local Rohde & Schwarz representative.

After the external correction procedure, reboot the instrument.

2.3 Internal Adjustments

All internal adjustments are available in the **Setup/Internal Adjustments** menu (see operating manual).

Performing **Setup/Internal Adjustments/Adjust All** activates all internal adjustments in a reasonable order.

2.4 External Adjustments Requiring Measurement Equipment

The external adjustments have to be performed, if the recommended calibration interval is exhausted or RF modules or cables have been replaced.

The external adjustments require calibrated equipment and special software. Data sheet specifications of the unit are concerned. If required, contact your local Rohde & Schwarz representative.

2.5 Adjustment of internal Reference Frequency

When set to internal reference mode, the frequency accuracy of the synthesizer is determined by a 10 MHz VTCXO or a highly stable OCXO (Option R&S SGS-B1). The internal frequency source is set to a calibrated frequency standard at the R&S factory. This oscillator is subject to ageing and hence its output frequency can be adjusted.

2.5.1 Adjustment

Important: Allow the DUT to warm up for at least 20 minutes before adjustment is executed

- | | |
|----------------|--|
| Test equipment | - External frequency counter (1 Hz to RF_{max} , resolution 0.1 Hz) |
| Test setup | ➤ Connect a calibrated external frequency counter to the reference output at the rear panel. |
| Adjustment | ➤ Setting on DUT: |
- PRESET**
- Setup Menu
- Protection
- Protection Level 2 = 147946 ENTER
- Setting on spectrum analyzer (external frequency counter):
- MKR SIGNAL COUNT**
- MKR / NEXT CNT RESOL 0.1 Hz**
- Adjust the TCXO/ OCXO Calibration Value (Reference Oscillator – Adjustment - DAC Value) for an external frequency counter reading of 10 MHz, with minimal error.
 - Set the found value as TCXO/OCXO Custom Calibration Value in the Service menu (Service – Ext. Adjustment – TCXO/OCXO Adjustment - Calibration Value).
 - Press **Write Value to Eeprom** to permanently save the calibration value.

2.6 Internal Self Test

After each module replacement, it is recommended to perform the internal self test (refer to chapter 3, "[Troubleshooting with Internal Selftest](#)"). The self test checks the instrument by measuring internal diagnostic points and verifies whether the generator is operating properly.

If a self test failure occurs, check again whether all cables are properly connected. If the self test fails continuously, contact your local service center.

3 Repair

A schematic of the signal generator's design is presented below as block diagram at module level

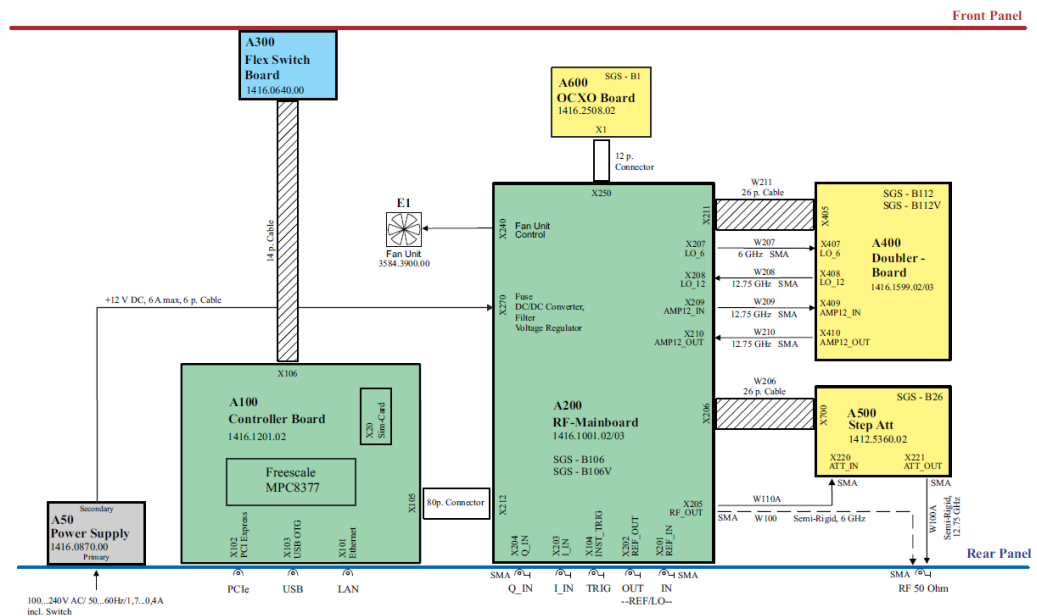

The R&S SGS100A consists of very few main modules and very few connections between these modules. The main units are:

- Power Supply
- Controller Board which includes all digital external interfaces, the main CPU, the hardware drivers for the front panel and the Interface to the RF Mainboard.
- Front Unit consisting of the flexible switch board with keys and LED indicators
- RF Mainboard containing the basic RF functionality, the instrument analog and RF connectors and interfaces to all other modules and HW options.
- Doubler Board (Option R&S SGS-B112 or R&S SGS-B112V) containing RF circuitry to extend the frequency range.
- Step Attenuator (Option R&S SGS-B26) containing RF circuitry to extend the level dynamic range.
- Reference Oscillator (Option R&S SGS-B1) which is plugged directly onto the RF Mainboard.
- Fan Unit for forced cooling of the instrument modules

A detailed description of these modules is given in section "[Functional Description](#)" on page 52.

3.1 Functional Description

3.1.1 Power Supply Module

The power supply module provides a single 12 V supply voltage for the operation of the signal generator. It can be switched on and off by means of the power switch on the rear panel.

The power supply works over a wide input voltage range from 100 V to 240 V ($\pm 10\%$) and AC supply frequencies from 50 Hz to 60 Hz ($\pm 5\%$). The power factor correction meets EN 61000-3-2.

The secondary voltage is open-circuit-proof and short-circuit-proof.

The primary fuses are located inside the power supply module and cannot be replaced.

Further fuses are fitted on the RF Mainboard as a means of fire protection.

3.1.2 Controller Board

The Controller Board of the signal generator involves the following components and modules:

3.1.2.1 Switching regulators

Switching regulator modules for 1.0 V, 1.2 V, 1.8 V and 3.3 V supply voltages.

3.1.2.2 Controller

Central Controller of the R&S SGS100A including all memory devices and external interfaces.

3.1.2.3 FPGA (SIGMA_COM)

Performs data processing for the serial buses, which send setting data to the modules. It also contains the controllers for the SmartCard, the Keyboard and LEDs. The SIGMA_COM is configured via an SPI-Interface of the processor.

3.1.2.4 Diagnostic Multiplexer

The diagnostic Multiplexer is used for measuring the supply voltages of the Controller Board during failure diagnostic.

3.1.2.5 EEPROM

The following data is stored here: Serial number of the instrument, header line data of the board.

3.1.2.6 Temperature sensor

A temperature sensor mounted on the Basis Board monitors the temperature. If a defined temperature above the guaranteed maximum operating temperature is exceeded, the modules in the instrument are switched off. So the R&S SGS100A secures itself against damage due to overheating.

3.1.3 RF Mainboard

The RF Mainboard contains the basic analog hardware of the instrument. The RF signal is generated by a synthesizer that can be locked to internal or external reference frequency sources. Analog IQ modulation can be performed when the vector modulation option is equipped. The output level is controlled by a level control loop controlling the level driving the instrument output or the optional step attenuator. The RF Mainboard is controlled by the Controller Board via a serial bus and additional control signals.

3.1.3.1 Block diagram

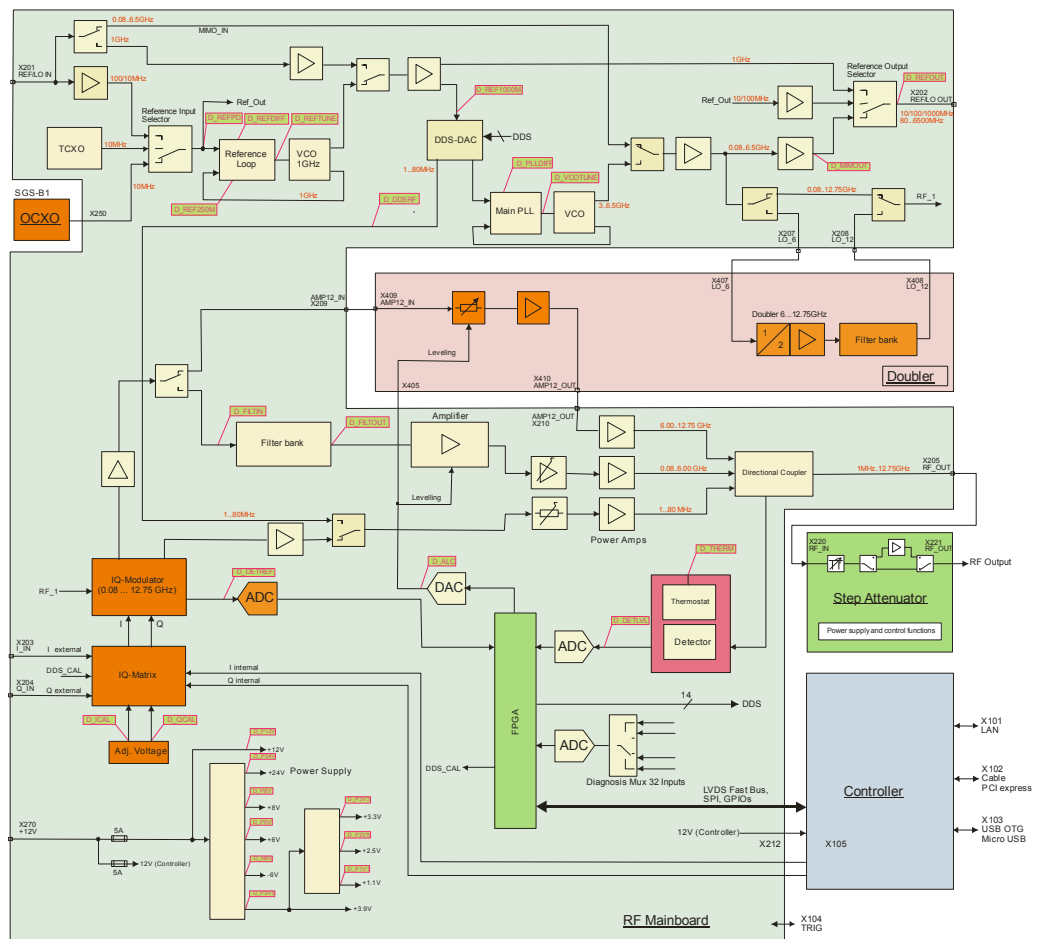

3.1.3.2 Implemented functions

- Reference crystal oscillator and reference frequency switch
- Synthesizer
- DDS module
- Vector modulator (Option)
- Phase coherent input / output (Option)
- Harmonics filter
- RF amplifiers
- Level control
- Diagnostics
- Power supply for optional RF modules
- Control interface for optional RF modules

3.1.3.3 Internal and external reference

The instrument reference frequency is determined either by the signal supplied by the built-in 10 MHz TCXO or 10 MHz OCXO (A600 OCXO Board) or by an external reference signal that is fed to the input X201 REF/LO IN. The external reference frequency can be set to 10 MHz / 100 MHz / 1000 MHz. The output X202 REF/LO OUT provides a buffered reference frequency signal, which has been derived from the active reference source. In internal reference mode, the frequency of the TCXO / OCXO can be adjusted by a DAC.

3.1.3.4 Main 1000 MHz oscillator

A built-in 1000 MHz Oscillator delivers the internal reference signal for the DDS based Synthesizer. This source is synchronized to the selected reference signal (internal TCXO / OCXO or external applied signal) with a PLL. When using an external 1000 MHz reference signal, the internal 1000 MHz source is switched off.

3.1.3.5 RF Synthesizer/ DDS module

The 1000 MHz signal of the main oscillator provides the system clock for the DDS module. The RF output signal in the frequency range from 1 MHz to 80 MHz is generated directly by the DDS. The analog RF signal is then low pass filtered, amplified and fed to the module RF output.

For RF output frequencies above 80 MHz the DDS generates a signal with high resolution, which is applied as reference signal to the main PLL of the RF frequency synthesizer. In the synthesizer a VCO is locked to the reference frequency using a fractional-n-PLL. The VCO output signal is then fed to fixed frequency dividers which are set to appropriate divider ratios to generate the RF signal from 80 MHz to 6.5 GHz. The synthesizer signal can also be fed into the optional doubler board to extend the synthesis output frequency range up to 12.75 GHz. The synthesis signal can also be switched to the REF/LO OUT connector in phase coherent LO operation mode.

3.1.3.6 Vector modulator

The synthesizer / doubler board signal can be routed directly to the following RF chain or the optional vector modulator, which can multiply the signal by the external analog I/Q signals. The vector modulator LO signal can also be taken from the REF/LO IN connector in phase coherent LO operation mode.

3.1.3.7 Harmonics filters

The output signal of the frequency dividers is a square wave signal. To reach the guaranteed harmonic performance (see datasheet) the harmonics of the RF signal have to be suppressed. Due to the wide RF frequency range multiple filters are needed. The different filters are selected according to the RF output frequency and their cut off frequency. They are inserted into the RF signal path by the means of RF switches.

3.1.3.8 Automatic Level control

With the means of a directional coupler a small part of the output signal of the power amplifier is fed to an RF detector. The output signal of this RF detector is fed to the Automatic Level Control (ALC) unit. The ALC sets the Level Control Voltage controlling the variable attenuators to reach the desired output level.

3.1.3.9 Fan Controller

The fan for cooling the RF modules is connected to the RF Mainboard and controlled according to the temperatures of the Controller Board, RF Mainboard, Doubler Board and Step Attenuator. The highest observed temperature determines the fan speed.

3.1.3.10 Supply voltage control and filtering

The supply voltages required for the RF Mainboard and the optional HW modules are generated by switched mode converters and filtered by means of passive filtering and additional active voltage regulators. Linear regulators with very good noise and distortion suppression characteristics have been implemented based on operational amplifier circuitry.

3.1.4 Doubler Board

3.1.4.1 Doubler Board architecture

The option incorporates a frequency doubler from 3.25 GHz ... 6.375 GHz to 6.5 GHz ... 12.75 GHz and means for level control and amplification for the frequency range from 6 GHz ... 12.75 GHz. Frequency doubler and RF-chain are connected to the RF Mainboard such that the frequency range of the combination extends to 12.75 GHz in CW mode as well as in vector modulated mode. The doubler board includes an Eeprom to store specific data, a temperature sensor and a diagnosis system. Control and power supply is provided by the RF Mainboard.

3.1.4.2 Doubler Board diagram

The following diagram shows the two separated RF-paths of the Doubler Board consisting of a doubler-path and a RF-chain.

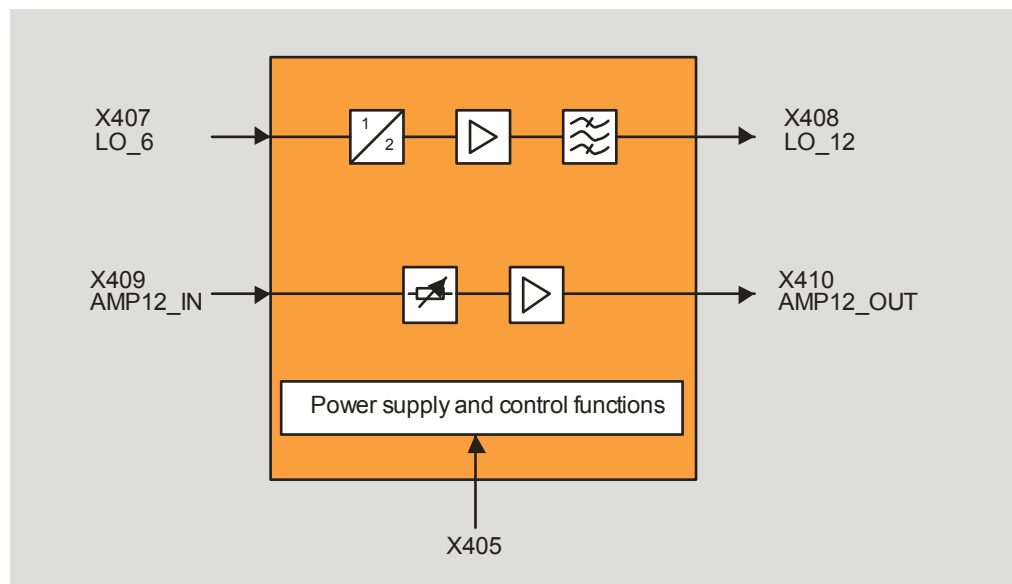

Figure 3-1: Doubler Board diagram

3.1.5 Step Attenuator

3.1.5.1 Step Attenuator architecture

The dynamic range of output power from the RF Mainboard is limited due to several technical restrictions. To achieve very high and extremely low output levels an attenuator with high dynamic range is required at the output of the instrument. The attenuation can be switched in 6 dB steps from -114 dB to 0 dB nominal. To overcome the attenuator loss, an amplifier in the attenuator module output stage can be activated. The module includes an Eeprom to store specific data, a temperature sensor and a diagnosis system. Control and power supply is provided by the RF Mainboard.

3.1.5.2 Step Attenuator diagram

The following diagram shows the functional equivalent of the module:

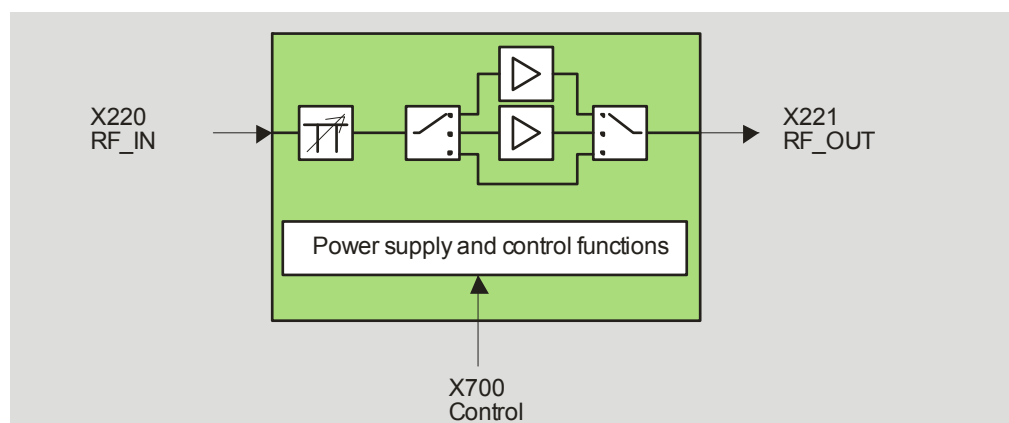

3.1.5.3 Power Amplifiers

To offer high output power levels despite of the insertion loss of the switching matrix there are two amplifiers which can be switched into the path at the output of the board. The amplifiers are split into frequency bands. There is one for the low frequencies from 1 MHz to 6.5 GHz and one for the range from 6.5 GHz to 12.75 GHz.

3.1.5.4 Voltage Regulators and filtering

There are two voltage regulators located at the board connector as the Step Attenuator is used in multiple instruments with different supply voltages. On the board itself great efforts have been spent to effectively filter all control voltages to ensure the required dynamic range.

3.1.6 R&S SGS-B1 Reference Oscillator

The option incorporates a highly stable 10 MHz OCXO. When attached to the RF Mainboard, the OCXO determines the reference frequency stability of the R&S SGS100A synthesizer in internal reference mode. The module includes an Eeprom to store specific information such as the frequency adjustment data. The Reference Oscillator module is plugged directly onto the RF Mainboard. Control and power supply is provided by the RF Mainboard.

3.2 Troubleshooting

The purpose of these troubleshooting instructions is to help to trace down malfunctions to board level. The instrument can thus be made ready for use again by means of board replacement.

If error tracing doesn't show clear results, we recommend that you ship your instrument to our experts in the service centers (see address list) for module replacement and further error elimination. Some module replacements involve calibration procedures requiring calibrated equipment and appropriate software.

DANGER



Danger of shock hazard

For module replacement, ensure that the instrument is switched off and disconnected from the power supply by removing the plug from the AC and DC power connector.

Read all safety instructions at the beginning of this manual carefully before module replacement!

NOTICE



Risk of damage to the boards

Be careful not to cause short circuits when measuring voltages at pins placed close together!

The following utilities are provided in the signal generator for easy diagnosis and can be controlled by the R&S SGMA GUI software:

- Internal self test
- Internal diagnosis test points
- Internal adjustments
- Info line with error messages and history of messages displayed in R&S SGMA GUI software

Note: *When problems occur, first check whether any connections (cables, plug-in connections of boards, etc) are damaged or wrongly connected.*

3.2.1 Measuring Equipment and Accessories

Item	Type of equipment	Specifications recommended	Equipment recommended	R&S order No.
1	DC voltmeter		R&S URE3	0350.5315.03
2	Spectrum analyzer	Frequency range 0 to 26 GHz	R&S FSQ	1155.5001.26
3	Multimeter		-	
4	Oscilloscope	Bandwidth \geq 100 MHz	Hameg HM1500-2 or similar	

3.2.2 Switch-On Problems

After switching on the AC power supply via the switch on the back of the instrument, the following steps happen during the boot process:

Step	Visible Effect	Operational Requirements
1	Green power LED lights up without flashing	<ul style="list-style-type: none"> ➤ AC Power supply ok, ➤ 12 V Fuse on RF Board ok, ➤ Connection from RF Board to Controller Board ok, ➤ 1.0 V and 3.3 V switching regulator on Controller Board ok, ➤ Connection of green Front Panel keypad foil to Controller Board ok.
2	After 1 second: Green power LED starts flashing, LED on Controller Board lights up.	<ul style="list-style-type: none"> ➤ Controller operational and starts booting, ➤ Successful loading of FPGA configuration.
3	After 40 seconds: Green power LED again lit steadily	<ul style="list-style-type: none"> ➤ Firmware installation intact ➤ Booting successful
4	Device can be accessed from SGMA-Gui via any of the remote control ports.	<ul style="list-style-type: none"> ➤ Used port intact and operational

• Error: boot process step 1 not reached

Action	Possible error causes and further steps
Check voltage on power supply module output (12.0 V ... 12.3 V). ↓	Short circuit on secondary side. Disconnect power supply module from RF-Board and recheck voltage on power supply module. If it still does not match the rated value, replace power supply module. If voltage is correct now, reconnect boards and fan one by one and search this way for the module, which causes the short circuit.
Check Fuses on RF Board. ↓	If fuses are blown, proceed as described in section " <i>Fuses</i> " on page 71.
Check 12 V supply voltage on Controller Board ↓	Either Controller Board or RF-Board is defect.
Check 1.0 V (0.95 V...1.05 V) and 3.3 V (3.15 V...3.45 V) supply voltages on Controller Board. ↓	If voltages do not match the rated value, replace Controller Board.
Check green LED on Controller Board	If LED is lit, then green Front Panel keypad foil is defect or not connected properly to Controller Board.

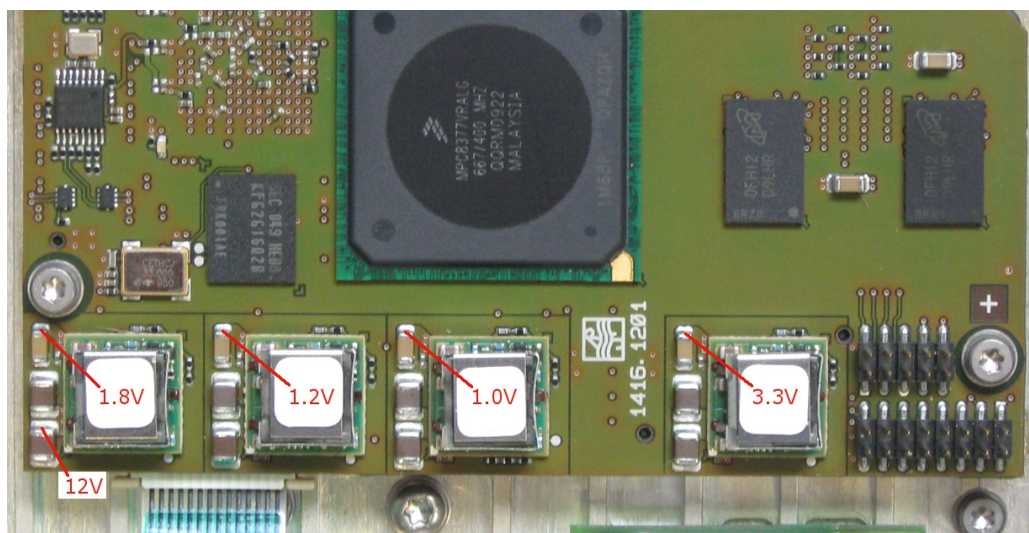

The screws of the RF-Board shield may be used as ground potential for the measurements.

- **Error: boot process step 2 or 3 not reached**

Action	Possible error causes and further steps
Try to reinstall Firmware via Recovery System.	If not possible, replace Controller Board.

- **Error: boot process step 4 not reached**

Action	Possible error causes and further steps
Try different remote control port (USB, Ethernet, PCI Express).	If only one port is not working, check your cabling and look out for LAN related problems. If no other reason is found, replace Controller Board.

3.2.3 Keyboard and LED Test

- This **utility** allows you to check for proper operation of all front panel elements

Normal action	Error, possible causes and corrective action
<p>Test called by SGMA-GUI with Diagnostic/Test – Other Tests - Keyboard Test - On</p> <p>or by remote command :TEST:KEYBoard[:STATe] ON</p> <p>All LEDs except the Power/Standby indicator change to orange.</p> <p>Pressing the keys in the order RF ON – LAN - ID changes the color of all LEDs except the Power/Standby indicator simultaneously to Red – Off -Green.</p> <p>Exit the test mode by SGMA-GUI with Diagnostic/Test – Other Tests - Keyboard Test - Off</p> <p>or by remote command :TEST:KEYBoard[:STATe] OFF</p>	<p>If the LEDs except the Power/Standby indicator do not light in orange color, the front panel is defective. Change the front panel.</p> <p>If the color does not change according to the description, a malfunction has occurred. If the color remains unchanged after actuation, the key is defective.</p> <p>In either case: Change the front panel.</p> <hr/> <p>Note: <i>The test can not output internally generated pass/fail information. The user must decide whether a malfunction has occurred.</i></p> <hr/>

3.2.4 Troubleshooting with Internal Selftest

The internal self test checks the instrument by setting different internal states and measuring internal diagnostic points.

Execute **Diagnostic/Test - Selftest- Selftest**. The self test reports the modules failing the test:

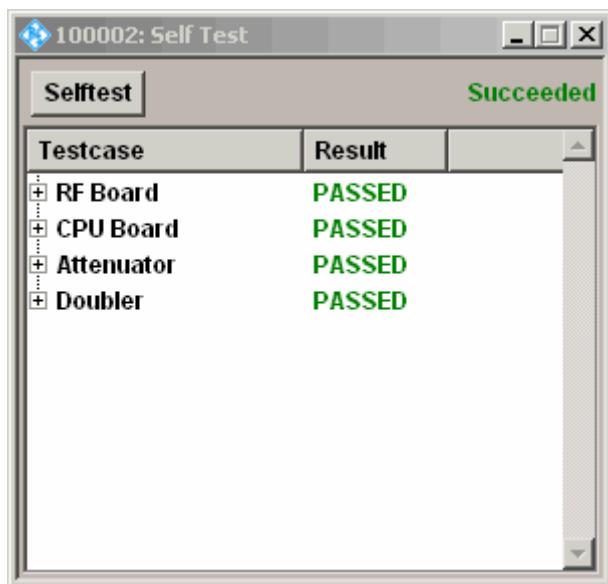

To see the details of the self test open the corresponding branch of the result tree:

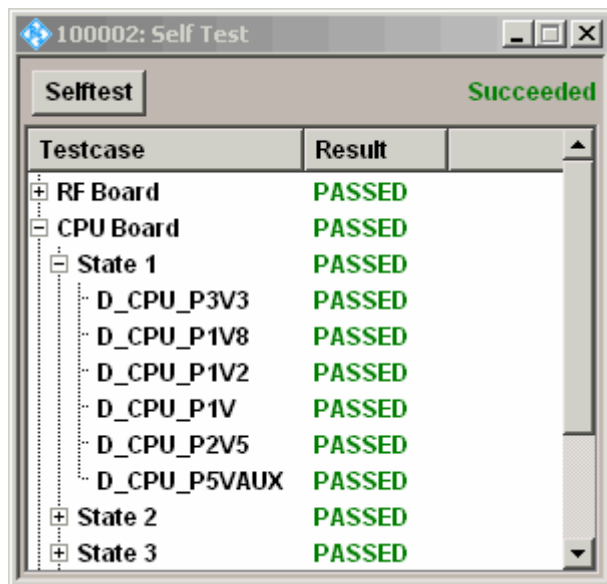

3.2.5 Troubleshooting with Internal Adjustments

Various internal adjustments are necessary for correct operation of the instrument. The failure of a certain adjustment can shorten troubleshooting considerably. The affected module is the RF Mainboard and the installed R&S SMB-B112 Doubler Board.

Note: Failed internal adjustments can also be queried on the info page -> History.

Normal action	Error, possible causes and corrective action
<p>Internal adjustments call: Setup - Internal Adjustments - Adjust All Internal adjustment of the RF Mainboard and the optional R&S SMB-B112/-B112V Doubler Board is executed.</p>	<p>Abort during adjustment:</p> <p>The synthesis, level and vector modulator adjustments in the standard frequency range up to 6 GHz are carried out exclusively on the RF Mainboard using the Diagnostic A/D converter on the Module. Adjustments concerning the extended frequency range from 6 GHz to 12.75 GHz use diagnostic system of the Doubler Board option and the Diagnostic A/D converter on the RF Mainboard.</p> <p>If the synthesis or vector modulation adjustment fails most probably the RF Mainboard is defective. Check the RF Mainboard being supplied correct (see page 71).</p> <p>If the level adjustment fails in an instrument without Doubler Board most probably the RF Mainboard is defective. Check the RF Mainboard being supplied correct (see page 71).</p> <p>If the level adjustment fails in an instrument with Doubler Board most probably the RF Mainboard is or the Doubler Board is defective. Check the connection of ribbon cable W211. Perform the instrument self test (see page 50).</p>

3.2.6 Instrument Faults

The following table lists R&S SGS100A faults. For every fault additional test are described to determine the defective module.

Fault	Test	Action if test fails
RF Output Level is wrong	R&S SGS100A settings: <ul style="list-style-type: none"> • Instrument Preset • Reference Oscillator ➔ Source Int • RF on • Mod off • Level = 15 dBm Measure the Output Level with a power meter across the frequency range. The difference between set and measured level has to be lower than guaranteed in the datasheet.	Instrument without step attenuator: Check the mating torque of the SMA-connector at cable W100 being 60 Ncm. Most probably the RF Mainboard is defective. Check the RF Mainboard being supplied correct (see page 71). Instrument with step attenuator option: Check the connection of ribbon cable W206. Check the mating torque of the SMA-connectors at cables W100A and W110A being 60 Ncm. Most probably the RF Mainboard or the Step Attenuator is defective. Check the RF Mainboard being supplied correct (see page 71).

Fault	Test	Action if test fails
RF Output Frequency is wrong	R&S SGS100A settings: <ul style="list-style-type: none"> • Instrument Preset • Setup ➔ Internal Adjustment ➔ 'Adjust all' • Reference Oscillator ➔ Source Ext • Reference Oscillator ➔ Ext Ref Input Frequency 10 MHz • RF on • Mod off • Level: 0 dBm • Frequency = 1 GHz Supply an external 10 MHz reference signal meeting the level and frequency specification given in the datasheet. Measure output frequency with a spectrum analyzer or a frequency counter synchronized to the same reference. The frequency error has to be < 0.1 Hz.	Most probably the RF Mainboard is defective. Check the RF Mainboard being supplied correct (see page 71).
	R&S SGS100A setting: <ul style="list-style-type: none"> • Reference Oscillator ➔ Source Int • Reference Oscillator ➔ Output Frequency 10 MHz • Reference Oscillator ➔ REF/LO Output REF Measure the 10 MHz reference output signal with spectrum analyzer or frequency counter and power meter. Output frequency and level have to meet the specifications given in the data sheet.	Without Reference Oscillator B1 being equipped most probably the RF Mainboard is defective. Check the RF Mainboard being supplied correct (see page 71). If the R&S SGS100A is equipped with Reference Oscillator R&S SGS-B1 remove the unit (see page 110) and perform this test again. If it works most probably the Reference Oscillator B1 is defective. Check the Reference Oscillator being supplied correct (see page 71).

Fault	Test	Action if test fails
Poor Harmonic Distortion	R&S SGS100A settings: <ul style="list-style-type: none"> • Instrument Preset • Reference Oscillator ➔ Source Int • RF on • Mod off • Level ➔ Mode Normal • Level ➔ Setting Characteristic ➔ Auto • Level = Maximum guaranteed level for harmonic distortion (see datasheet) Measure the level of the fundamental frequency with a spectrum analyzer. The level of every harmonic has to be at least 30 dB lower than the level at the fundamental frequency. Repeat this test over the frequency range of the instrument.	Instrument without step attenuator: Most probably the RF Mainboard is defective. Check the RF Mainboard being supplied correct (see page 71). Instrument equipped with Step Attenuator: Most probably the RF Mainboard or the Step Attenuator is defective. Check the connection of ribbon cable W206. Check the RF Mainboard being supplied correct (see page 71).

Fault	Test	Action if test fails
Slow Settling times	Settling times are defined for PCI express remote control only. The settling time is the time-delay after the remote control command arrives at the R&S SGS100A until level and frequency are within the given tolerance from their final values. Be careful not to measure with an instrument drifting on its own due to applying the RF from the R&S SGS100A.	Most probably the RF Mainboard is defective. Check the RF Mainboard being supplied correct (see page 71).

Fault	Test	Action if test fails
10 MHz / 100 MHz / 1000 MHz Reference Input faulty	<p>Check the 10 MHz / 100 MHz / 1000 MHz reference signal fed into the R&S SGS100A with a spectrum analyzer or frequency counter and power meter. If level and frequency of this signal is matching the specification in the datasheet set the R&S SGS100A to:</p> <ul style="list-style-type: none"> • Instrument Preset • Reference Oscillator ➔ Source Ext • Reference Oscillator ➔ Ext Ref Input Frequency 10 MHz / 100 MHz / 1000 MHz • RF on • Mod off • Frequency = 1 GHz • Level = 0 dBm <p>Check for error Messages. No "External Reference Errors" are allowed to occur.</p> <p>Measure output frequency with a spectrum analyzer or a frequency counter synchronized to the same reference. The frequency error has to be < 0.1 Hz.</p>	<p>Most probably the RF Mainboard is defective. Check the RF Mainboard being supplied correct (see page 71).</p>

Fault	Test	Action if test fails
10 MHz / 1000 MHz Reference Output faulty	R&S SGS100A setting: <ul style="list-style-type: none"> • Instrument Preset • Reference Oscillator ➔ Source Int • Reference Oscillator ➔ Output Frequency 10 MHz / 1000 MHz Measure 10 MHz / 1000 MHz reference output signal with spectrum analyzer or frequency counter and power meter. Output frequency and level have to meet the specifications given in the data sheet.	<p><i>R&S SGS100A without Reference Oscillator</i> <i>R&S SGS-B1:</i> Most probably the RF Mainboard is defective. Check the RF Mainboard being supplied correct (see page 71).</p> <p><i>R&S SGS100A with Reference Oscillator</i> <i>R&S SGS-B1:</i> Remove the Reference Oscillator B1 (see page 110) and perform this test again. If still failing most probably the RF Mainboard is defective. Check the RF Mainboard being supplied correct (see page 71). If the 10 MHz / 1000 MHz reference signal is in tolerance most probably the Reference Oscillator B1 is defective. Check this module being supplied correct (see page 71).</p>

Fault	Test	Action if test fails
I/Q ext Input Faulty	R&S SGS100A settings: <ul style="list-style-type: none"> • Instrument Preset • Reference Oscillator ➔ Source Int • RF on • Mod on Measure the input resistance of the I/Q Input SMA connector with a multimeter. The input resistance should be $50 \Omega \pm 10 \%$.	Most probably the RF Mainboard is defective. Check the RF Mainboard being supplied correct (see page 71).

Fault	Test	Action if test fails
Vector Modulation faulty	<p>The vector modulation performance is specified only up to the Peak Envelope Power (PEP) noted in the datasheet. Ensure the internal IQ adjustment was performed successfully.</p> <p>The vector modulation performance has to match the values given in the datasheet. Measure with a vector signal analyzer with sufficient performance, i.e. an R&S FSQ spectrum analyzer.</p>	Most probably the RF Mainboard is defective. Check the RF Mainboard being supplied correct (see page 71).

Fault	Test	Action if test fails
Trigger Input / Output faulty	This signal is driven from the RF Mainboard FPGA and the Trigger Input / Output SMA connector is directly fitted onto the RF Mainboard as well.	Most probably the RF Mainboard is defective. Check the RF Mainboard being supplied correct (see page 71).

Fault	Test	Action if test fails
Faulty Remote interface PCI express, USB or LAN	All remote interfaces including the interface connectors are fitted directly on the Controller Board.	Most probably the Controller Board is defective. Check the Controller Board being supplied correct (see section " Switch-On Problems " on page 60).

Fault	Test	Action if test fails
Instrument switches off, error message "Emergency shutdown" appears	<p>Check if fan operates during instrument boot procedure.</p> <p>Check if fan operation is constrained by dust etc.</p>	<p>Remove and clean the fan unit.</p> <p>If necessary, replace the fan (see page 108).</p>
	Check ambient temperature.	Ensure proper cooling of the instrument and do not limit the air flow. Operate the instrument inside the ambient temperature specifications.

3.2.6.1 Fuses

Switch on the R&S SGS100A and measure the voltage at fuse F2800.2. If the Voltage is less than 12 V, change the power supply.

If the voltage is o.k., measure the voltage at fuse F2800.2. If the voltage is much lower than 11.9 V, then fuse F2800 is blown and most probably the Controller Board (1416.1201) is faulty. Replace the fuse with the correct type given by the table below and check the Controller Board (see section "[Switch-On Problems](#)" on page 60).

Measure the voltage at fuse F2801.1. If the voltage is much lower than 11.9 V, then fuse F2801 is blown. The fuse might be blown due to a defective module other than the RF Mainboard. If the fuse is blown, replace the fuse with the correct type given below. Remove the connections to the Doubler Board (X211) and the step attenuator ASATT13 (X206), if present. If the RF Mainboard is equipped with the Reference Oscillator R&S SGS-B1, remove this unit as well (see section "[Removing the OCXO Board](#)" on page 110). Switch on the R&S SGS100A and after two minutes check the voltage drop across fuse F2801 again. If the fuse is blown again, the RF Mainboard is defective and should be replaced.

If the fuse is o.k., switch off the R&S SGS100A again. If the R&S SGS100A is equipped with step attenuator, then connect the step attenuator ASATT13. Switch on the R&S SGS100A again. If the fuse is blown after two minutes, the step attenuator module ASATT13 (1412.5360) is defective and has to be replaced (see page 115).

If the R&S SGS100A is equipped with a Doubler Board, switch off the R&S SGS100A and connect this module to the RF Mainboard (X211). Switch on the R&S SGS100A again. If the fuse is blown after two minutes, the Doubler Board 1416.1601 is faulty and has to be replaced (see page 111).

If the R&S SGS100A is equipped with a Reference Oscillator R&S SGS-B1, then switch off the R&S SGS100A and insert the reference oscillator. Switch on the R&S SGS100A again. If the fuse is blown after two minutes the reference oscillator module (1416.2508) is defective and must be replaced (see page 110).

After replacement of defective modules don't forget to replace fuse F2800 and/or F2801 too!

RFMB revision (TAZ)	Fuse	Type	R&S Part Number	Manufacturer Part Number
up to 6.08	F2800	T5A	1090.4442.00	Littlefuse R452.005 NRL (MRL)
up to 6.08	F2801	T5A	1090.4442.00	Littlefuse R452.005 NRL (MRL)
from 6.09	F2800	FF7A	2079.5994.00	Littlefuse R451.007 NRL (MRL)
from 6.09	F2801	FF7A	2079.5994.00	Littlefuse R451.007 NRL (MRL)

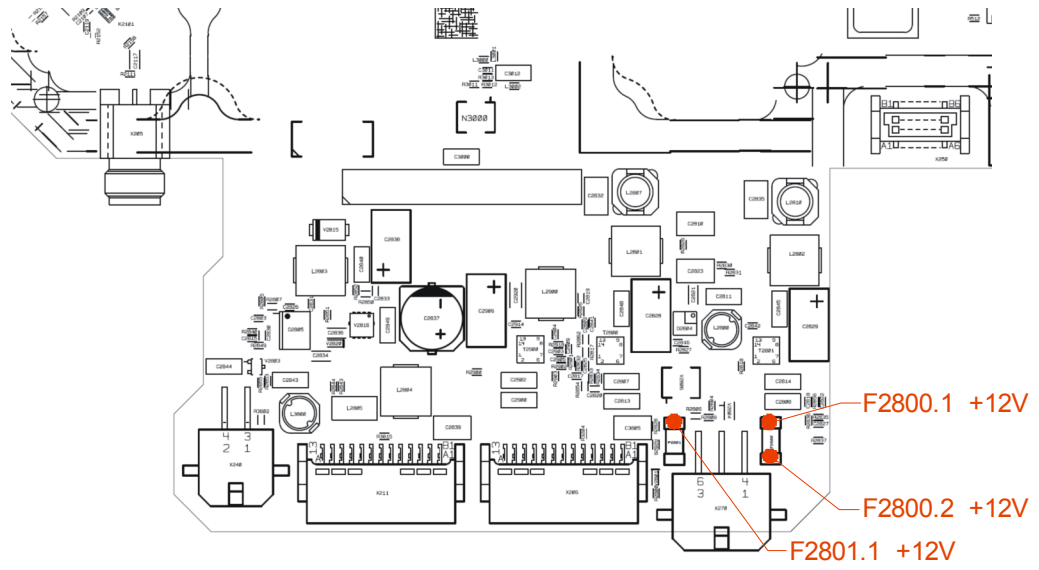

Figure 3-2: Position of the fuses on the RF Mainboard

3.2.7 Troubleshooting – RF Mainboard

The tests listed below ensure that an assumed error on the RF Mainboard is not caused by a defective or incorrectly connected cable, incorrect adjustment or another module.

3.2.7.1 Internal Adjustment “Adjust All”

A comprehensive test of the module is to run the internal adjustment.

Normal action	Error, possible causes and corrective action
Internal adjustments call: Setup – Internal Adjustments... - Adjust Synthesis Internal adjustment of the synthesizer on the RF Mainboard is executed. As result “Pass” is displayed.	Abort during adjustment: The adjustments are all carried out exclusively on the RF Mainboard. Most probably the RF Mainboard is defective. Check the board being supplied correctly (see page 74).
Internal adjustments call: Setup – Internal Adjustments... - Adjust Level Internal adjustment of the ALC Loop on the RF Mainboard is executed. As result “Pass” is displayed.	Abort during adjustment: If the adjustment fails even with disconnected Doubler Board, most probably the RF Mainboard is faulty. When the adjustment fails only with Doubler Board, the Doubler Board may be defective.
Internal adjustments call: Setup – Internal Adjustments... - Adjust IQ Modulator Internal adjustment of the IQ-Modulator on the RF Mainboard is executed. As result “Pass” is displayed	Abort during adjustment: The adjustments are all carried out exclusively on the RF Mainboard. Most probably the RF Mainboard is defective. Check the board being supplied correctly (see page 74).

3.2.7.2 Supply Voltages

Switch on the R&S SGS100A and measure the supply voltages of the RF Mainboard at the coils and capacitors near power supply connector (X270, see *Figure 3-3*). The measured voltages have to meet the values given in the table below. The voltage at V2806.5-8 may be switched off due to over temperature protection. The temperature of all modules should be less than 70 °C.

If not, turn off the R&S SGS100A and let all modules cool down, before you repeat these measurements. Be sure the fan is working correctly!

If one or more of the voltages are out of tolerance, the RF Mainboard is faulty.

Measuring Point	Voltage (V)
Shielding enclosure	0 (GND)
V2806.5-8	+ 11.8 to + 12.5
L2810.2	+ 6.4 to + 6.7
L2807.2	+ 8.4 to + 8.6
C2838.2	- 6.6 to - 6.4
C2810.1	+ 24 to + 25
C2906.1	+ 4.2 to + 4.4
L2805.2	+ 11.5 to + 12.5

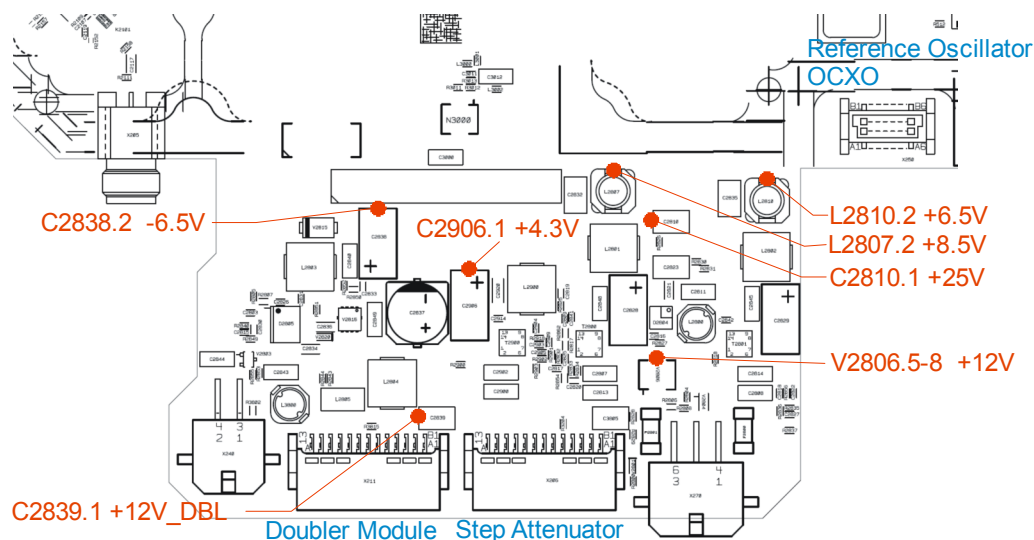

Figure 3-3: Power Supply and interface connectors of the RF Mainboard

3.2.7.3 Input and Output Signals

Connector, system	Signal name	Setting on signal generator	Frequency	Level	Signal flow
X205, SMA	RF_OUT	RF on	1 to 12750 MHz	-125 to +25 dBm	To RF connector at rear panel or step attenuator
X201, SMA	REF_IN	Ref External	Ref: 10/100/1000 MHz LO: 80 to 6500 MHz	0 to 16 dBm	External Reference or LO-Input
X202, SMA	REF_OUT	Ref/LO Output on	Ref: 10/100/1000 MHz LO: 80 to 6500 MHz	6 to 12 dBm	Reference or LO-Output
X203, SMA	I_IN	IQ-Modulation on	0 to 1000 MHz	-0.5 to +0.5 V	I-Input for Vector Modulation
X204, SMA	Q_IN	IQ-Modulation on	0 to 1000 MHz	-0.5 to +0.5 V	Q-Input for Vector Modulation
X207, SMA	LO_6	RF Frequency > 6500 MHz	3250 to 6375 MHz	4 to 7 dBm	To frequency doubler on doubler board
X208, SMA	LO_12	RF Frequency > 6500 MHz	6500 to 12750 MHz	9 to 12 dBm	From frequency doubler on doubler board
X209, SMA	AMP12_IN	RF Frequency > 6000 MHz	6000 to 12750 MHz	-5 to -12 dBm	To RF amplifier on doubler board
X210, SMA	AMP12_OUT	RF Frequency > 6000 MHz	6000 to 12750 MHz	-125 to +25 dBm	From RF amplifier on doubler board
X104, SMA	TRIG	---	---	LVC logic	Bidirectional trigger input/output

See also [Figure 3-4: Connectors](#).

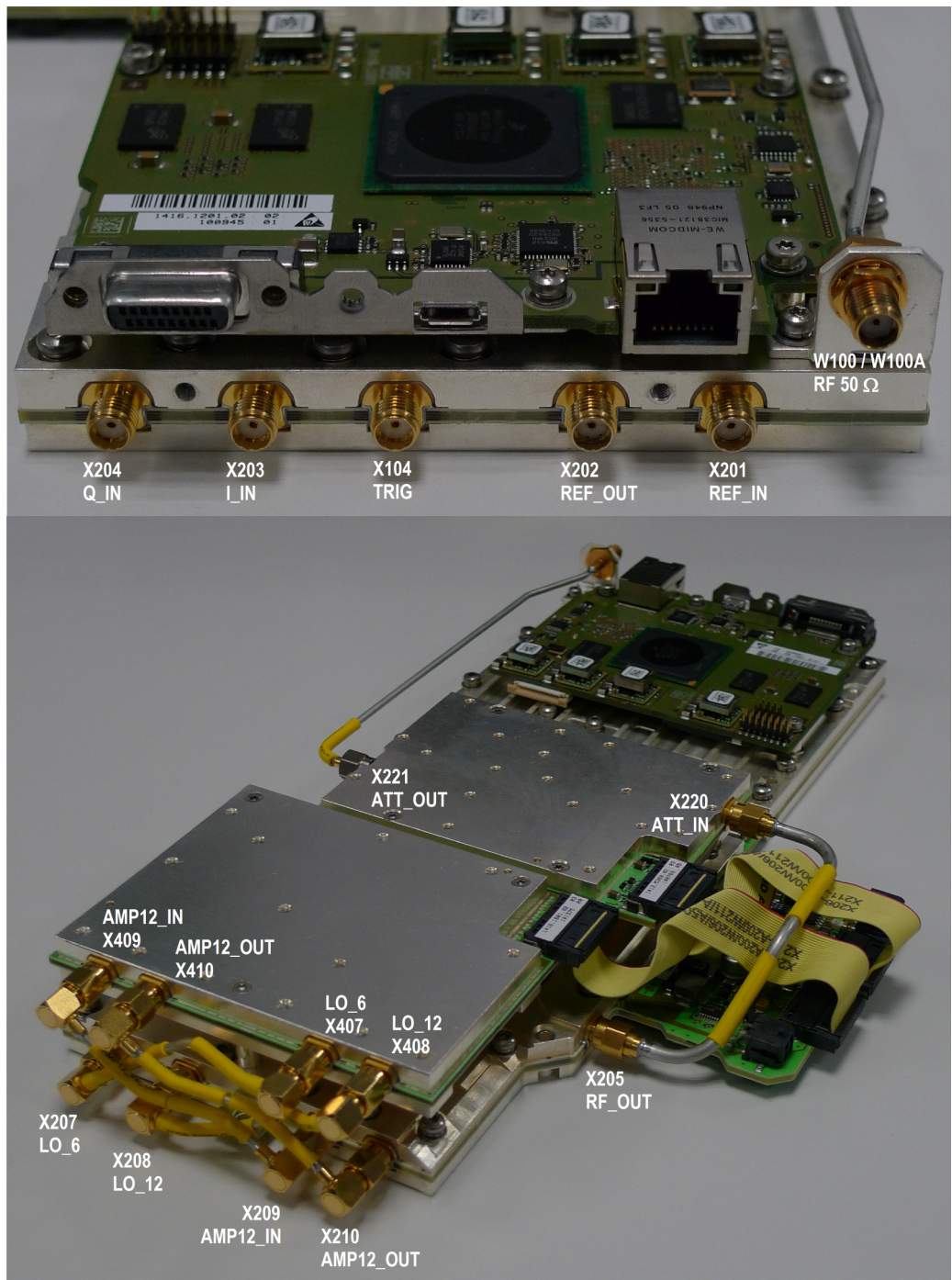

Figure 3-4: Connectors

3.2.7.4 Error Messages Concerning the RF Mainboard

Error message	Error correction
"ALC unlocked"	<ul style="list-style-type: none"> ➤ Execute Internal Adjustment "Adjust Level". ➤ Check if the output level is higher than the specified maximum output level. Reduce the output level. ➤ Set attenuator mode "Auto".
"Synthesis main-loop PLL unlocked"	<ul style="list-style-type: none"> ➤ Execute Internal Adjustment "Adjust Synthesis". ➤ If the error message does not disappear change the module.
"Reference PLL unlocked"	<ul style="list-style-type: none"> ➤ In case that the reference source is set to "external", check if the external reference is connected to the REF/LO Input. Are the level and the frequency error of the external reference signal as specified in the data sheet? ➤ If the reference source is set to "internal" troubleshoot the RF Mainboard with the internal diagnosis and check the OCXO R&S SGS-B1 (see section "Troubleshooting – Reference Oscillator option R&S SGS-B1" on page 78).
"Synthesis adjustment failed"	<ul style="list-style-type: none"> ➤ Execute Internal Adjustment "Adjust Synthesis". ➤ If error message does not disappear, check the diagnosis (see section "Troubleshooting with Internal Selftest" on page 63).
"Synthesis adjustment data invalid"	<ul style="list-style-type: none"> ➤ Execute Internal Adjustment "Adjust Synthesis". ➤ If the error message does not disappear, check the diagnosis (see section "Troubleshooting with Internal Selftest" on page 63).

3.2.7.5 Warnings Concerning the RF Mainboard

Warnings	Warning correction
"Pep value exceeds defined limit"	<ul style="list-style-type: none"> ➤ The peak envelope power (PEP) is higher than the set upper limit. ➤ Reduce the output level.

3.2.7.6 Frequency Error

Error	Error correction
Internal reference frequency: Frequency error greater than limit given in datasheet	<ul style="list-style-type: none"> ➤ Check if the error message "Reference PLL Unlocked" appears (see page 75). ➤ The frequency accuracy of the synthesizer is determined (set to internal reference) by a highly stable 10 MHz quartz oscillator that is set to a calibrated frequency standard at the R&S factory. This oscillator is subject to ageing and hence its output frequency can be adjusted (see chapter 2, "Adjustment of internal Reference Frequency"). <p>Note: <i>The internal reference can be impaired under the menu - Reference Oscillator... - Adjustment. This setting does not affect the factory adjustment and can be reset at any time by means of deactivation. If the tuning range is insufficient to reach the frequency error given in the datasheet the TCXO or OCXO on the RF Mainboard is defective. Replace the RF Mainboard if the R&S SGS comes without option R&S SGS-B1 otherwise see section "Replacing the OCXO Board R&S SGS-B1" on page 110.</i></p>

3.2.8 Troubleshooting – Reference Oscillator option R&S SGS-B1

3.2.8.1 Input and Output Signals

The Reference Oscillator has only one connector (X1) and is directly plugged into the RF Board (X250, see [Figure 3-5](#)). All signals and the supply voltage are fed to the module through this connector. Turn off the instrument and pull out the OCXO board. Turn on the instrument and check the following voltages:

Measuring Point	Voltage (V)
Shielding enclosure	0 (GND)
X250.B1	+ 3.3 to 3.4
X250.A1	+ 10.75 to + 11.25

If one or more of the voltages are out of tolerance, the RF Mainboard is faulty.

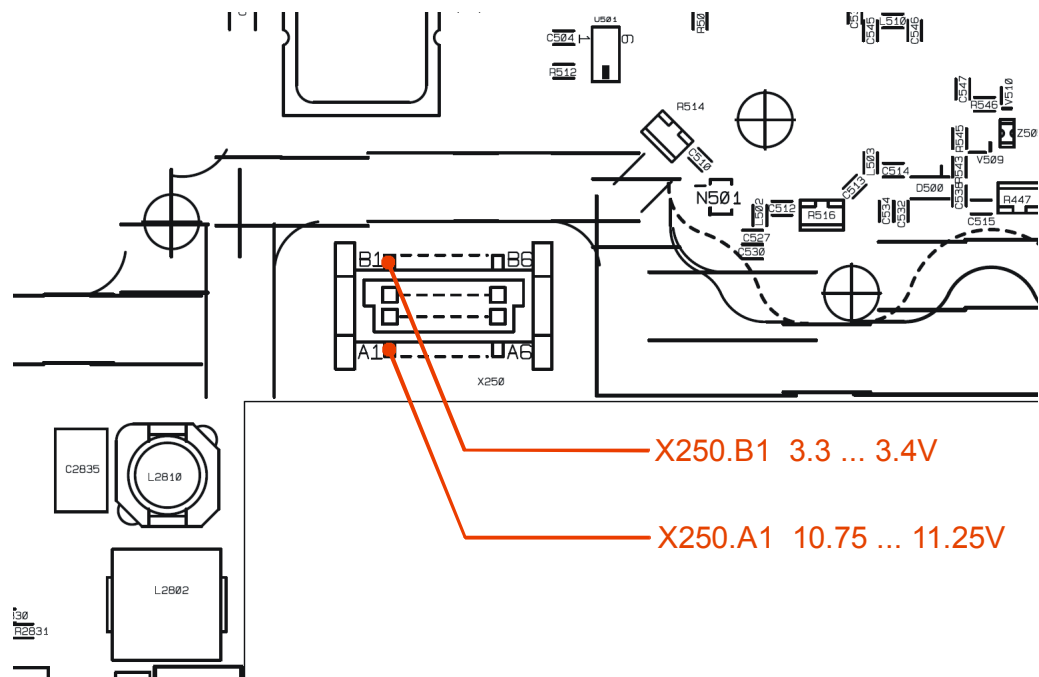

Figure 3-5: Pin locations X250 on RF Mainboard

Turn off the R&S SGS100A, plug in the OCXO board and power up the R&S SGS100A. Set reference source to “internal”.

The enable signal at G1.6 must have high-level (5.6 V to 5.8 V).

In the list under **setup – hardware config** should be the entry “OCXO”.

At pin G1.1 the output signal of the reference oscillator can be measured (10 MHz, 1 Vpp). If you notice a different behaviour, try a new tested OCXO board. If this still does not work, troubleshoot the RF Mainboard.

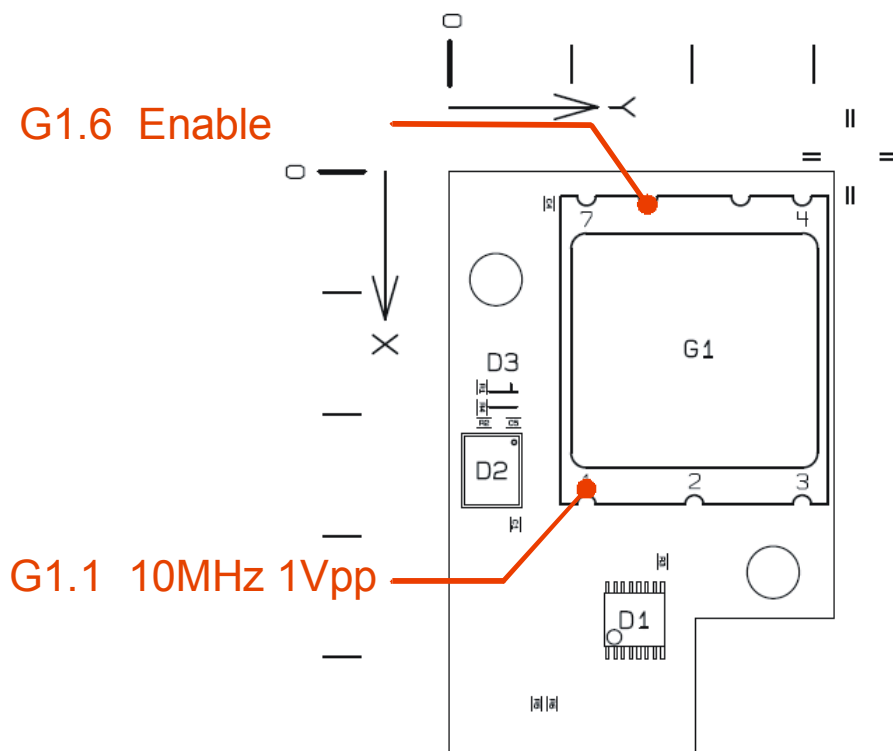

Figure 3-6: Pin locations on OCXO

3.2.8.2 Error Messages Concerning the Reference Oscillator Module

Error message	Error correction
"Reference oscillator oven cold"	<ul style="list-style-type: none"> ➤ Check the supply voltages of the module (see section "<i>Input and Output Signals</i>"). ➤ If the supply voltages are o.k. and this message does not disappear after 10 minutes, OCXO is defective. Change the module.
"Reference PLL unlocked"	<ul style="list-style-type: none"> ➤ Switch the R&S SGS100A to external Reference and supply a 10 MHz 10 dBm signal to the Ref/LO Input of the RF Mainboard. If the error message disappears and the R&S SGS100A is working correctly, the OCXO is defective, change the module.
"OCXO: cannot read EEPROM data" "OCXO: cannot store adjustm. data"	<ul style="list-style-type: none"> ➤ This indicates problems concerning the data transfer from and to the EEPROM of the module. If changing the module does not help, change the RF Mainboard.

3.2.8.3 Frequency Error, Reference Oscillator Adjustment

Error	Error correction
Internal reference frequency: Frequency error greater than limit given in datasheet	<ul style="list-style-type: none"> ➤ Check if the error message “Reference PLL Unlocked” appears (see page 75). ➤ The frequency accuracy of the synthesizer is determined (set to internal reference) by a highly stable oven controlled 10 MHz quartz oscillator that is set to a calibrated frequency standard at the R&S factory. This oscillator is subject to ageing and hence its output frequency can be adjusted (see chapter 2, “Adjustment of internal Reference Frequency”). <hr/> <p>Note: <i>The internal reference can be tuned by up to approx. $\pm 10^{-7}$ under the menu Reference Oscillator... - Adjustment. This setting does not affect the factory adjustment and can be reset at any time by means of deactivation. If the tuning range is insufficient to reach the frequency error given in the datasheet the OCXO is defective.</i></p> <hr/>

3.2.9 Troubleshooting – Active Step Attenuator

3.2.9.1 Supply Voltages

Remove the RF cables W100A, W110A from the Step Attenuator. Remove the Step Attenuator from the instrument and connect the module to the RF Mainboard using cable W206. Switch on the R&S SGS100A and measure the supply voltages of the Step Attenuator at the capacitors near its power supply connector (X700, see [Figure 3-7](#)).

CAUTION

Danger of hot surfaces

Do not run the Step Attenuator longer than 5 minutes without cooling.

The measured voltages have to meet the values given in the table below. If one or more voltages are not of the required level, check the Controller Board (see section "Switch-On Problems" on page 60).

Measuring Point	R&S SGS100A switched On
Shielding enclosure	GND
C600	+7.3 V to +8.5 V
C605	+11.5 V to +12.8 V
Z701	-8 V to -5.5 V

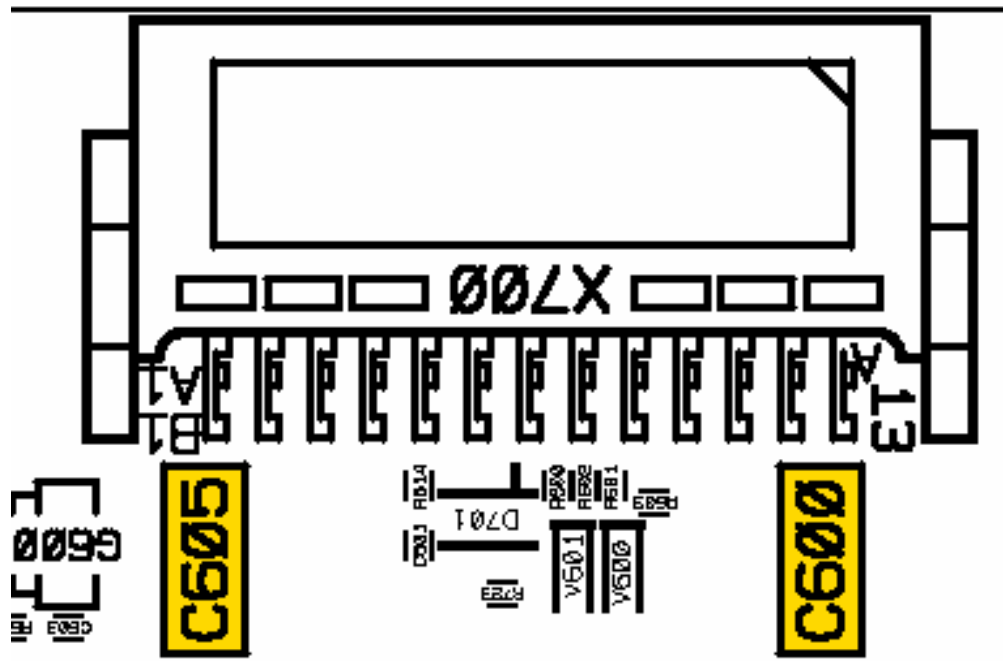

Figure 3-7: Power Supply Connector of Active Step Attenuator (top view)

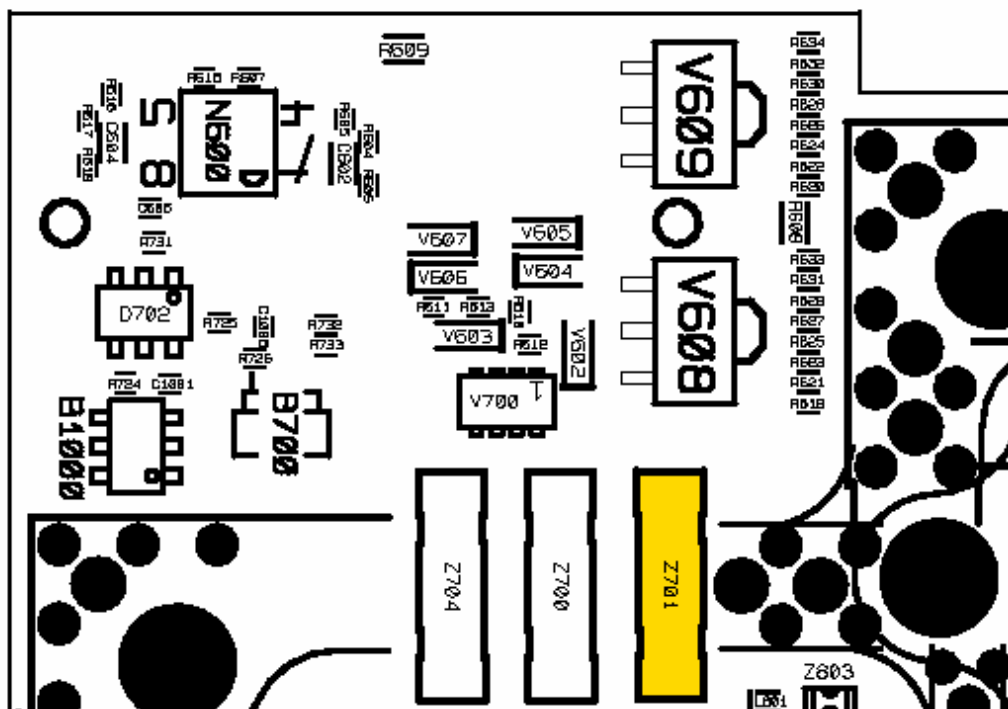

Figure 3-8: Power Supply Connector of Active Step Attenuator (bottom view)

If the supply voltages do not comply with the given values in the above table, change the connector cable and test again. If the supply voltages still do not comply, change the module.

3.2.10 Troubleshooting – Doubler Board option R&S SGS-B112/-B112V

3.2.10.1 Supply Voltages

Check the internal supply voltages of the Doubler Board with the internal diagnosis described in section "[Troubleshooting with Internal Selftest](#)" (diagnosis test points: D_P11V, D_P7V5, D_P6V, D_P5V, D_P3V3, D_N6V). If one or more tests fail remove the case (see page 87) and the EMC panel (see page 89), and check the supply voltages at the test points (at X405) according to [Figure 3-9](#).

The measured voltages have to meet the values given in the table below. If all voltages are of the required level, change the module.

If the supply voltages do not comply with the given values in the above table, change the connector cable W211 and test again. If the supply voltages still do not comply, check the voltages of the RF Mainboard (see section "[Supply Voltages](#)").

Test point	Voltage range
Shielding enclosure	GND
TP1	+7.5 V to +8.5 V
TP2	-7 V to -5.5 V
TP3	+6 V to +7 V
TP4	+11.5 V to +12.5 V

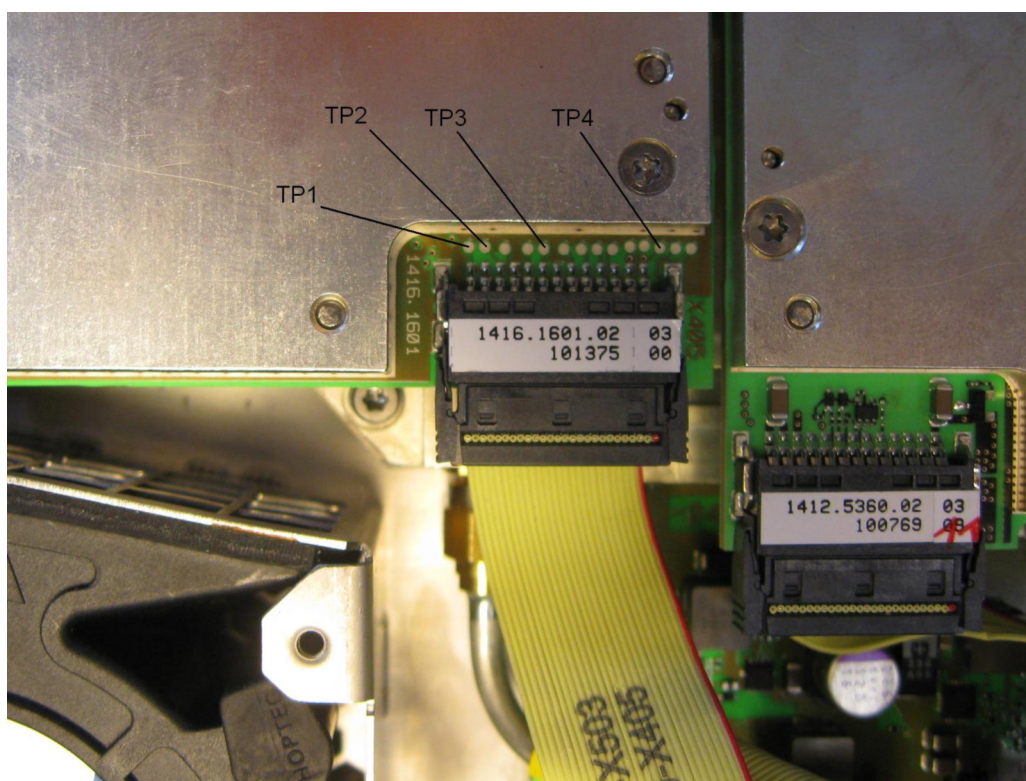

Figure 3-9: Location of the test points to measure the supply voltages

3.2.10.2 Input and Output Signals

Run the internal self test (see page 63) in order to check the internal RF-signals of the Doubler Board (diagnosis test points: D_DBL_IN, D_DBL_ALC, D_DBL_OUT, D_AMP_IN, D_AMP_OUT). If one of the tests at D_DBL_IN or D_AMP_IN fails, there is no input signal and probably the RF Mainboard or one of the RF-cables W207, W208, W209 and W210 is defective. If both of these tests pass and at least one of the other tests fail probably the Doubler Board is defective. In this case change the module.

3.3 Module Replacement and Upgrade

This section describes in detail the replacement of modules. Chapter 5 "[Documents](#)" provides information on how to order spare parts. It contains the list of mechanical parts with order numbers and the illustrations for module replacement.

WARNING

Danger of injury during module replacement

Any adjustments, replacement of parts, maintenance or repair must be carried out exclusively by technical personnel authorized by Rohde & Schwarz.

Follow the step-by-step instructions for module replacement carefully to avoid injury and ensure safe operation.

NOTICE

Risk of electrostatic discharge

Protect the work area against electrostatic discharge to avoid damage to electronic components in the modules. For details, refer to the safety instructions at the beginning of this manual.

Protection of mechanical components

Always use a torque wrench (60 Ncm) to fasten all RF connectors. Do not use an open-end wrench.

Protection of electronic components

Always wear gloves when handling the electronic components.

Datasheet compliance

Recalibration of the instrument is required after any disconnection or connection of RF cables.

3.3.1 Required Tools

- Star screwdriver TX 8
- Star screwdriver TX 20
- Hex Nut-Driver 5 mm
- Torque wrench 60 Ncm (8 mm)

3.3.2 Module Overview

Overview - Module Replacement

Module	Designation	Instrument Part No.	Replacement Part Order No.	Page Ref.
Power Supply (AC 90 V to 264 V)	A50	1416.0870.00	1416.0870.00	90
Controller Board	A100	1416.1201.02	1416.1201.02	98
RF Mainboard CW incl. in R&S SGS-B106	A200	1416.1001.03	1416.1001.03	93
RF Mainboard IQ incl. in R&S SGS-B106V	A200	1416.1001.02	1416.1001.02	93
Doubler Board CW, incl. in R&S SGS-B112	A400	1416.1601.02	1416.1601.02	111
Doubler Board IQ, incl. in R&S SGS-B112V	A400	1416.1601.03	1416.1601.03	111
Flex. Switch Board	A300	1416.0640.00	1416.0640.00	104
Step Attenuator incl. in R&S SGS-B26	A500	1412.5360.02	1412.5360.02	116
OCXO Board incl. in R&S SGS-B1	A600	1416.2508.02	1416.2508.02	110
Fan Unit	E1	3584.3900.00	3584.3900.00	108

Notes: All modules can be replaced by modules with the same part number or by replacement modules as listed above. The words "left" and "right" in the manual always refer to the front view of the instrument.

3.3.3 After Replacing an Assembly

After you have replaced one of the assemblies, certain adjustments, functional checks or performance tests have to be carried out. Please refer to chapter 2 "[Adjustment](#)".

3.3.4 Removing the Case

Put the instrument on the two front grips 1174.0018.00 (170).

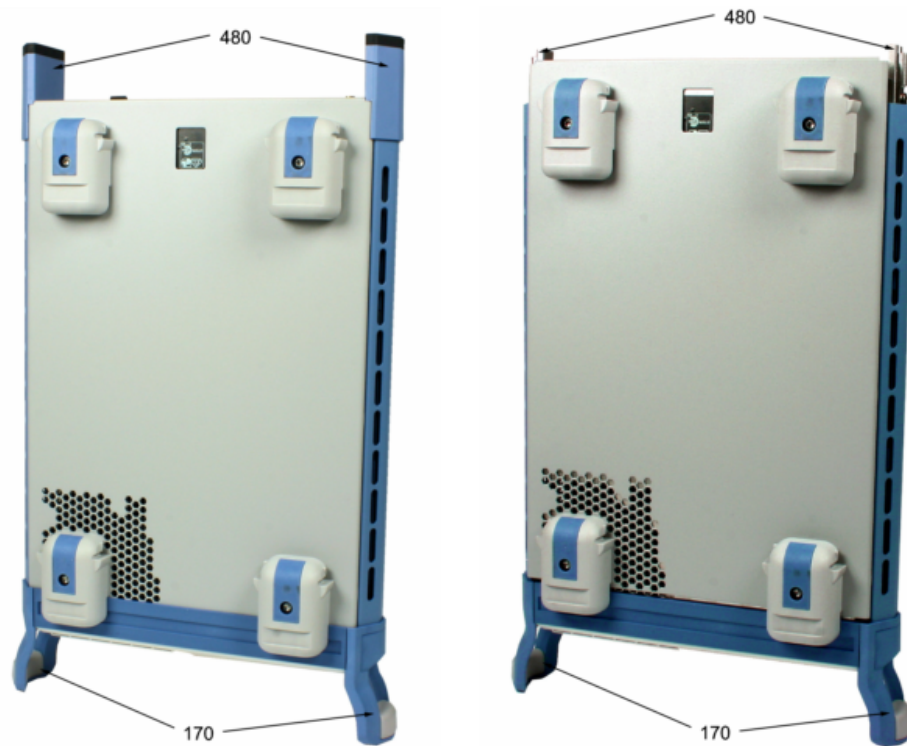

Unfasten the two rear feet 1174.0024.00 (480) on both sides and take them off.

To remove the two covers - lower 1416.0911.00 (350) and upper - 1174.0082.00 (380) first push the cover backwards and then remove it.

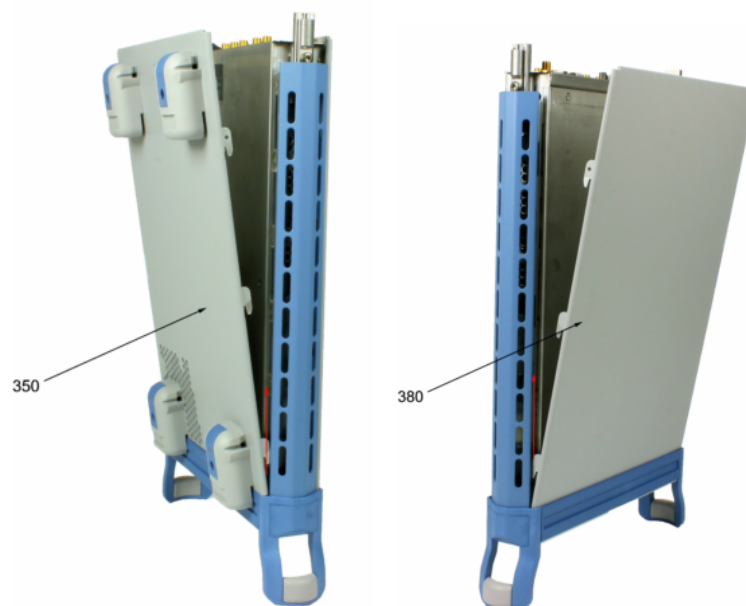

3.3.5 Installing the Case

1. Put the instrument on the two front grips 1174.0018.00 (170).
2. To install the covers - lower 1416.0911.00 (350) and upper - 1174.0082.00 (380) – first put the cover holders into the slots on the unit and then push it down.

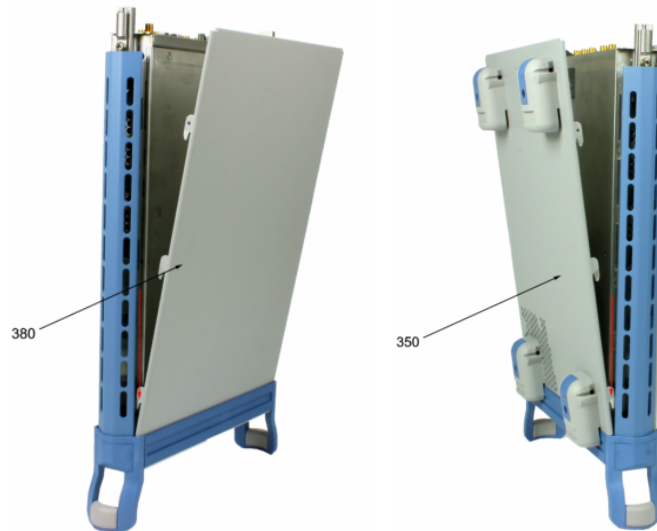

NOTICE

Risk of damage to the instrument.

Ensure that the power supply cord is disconnected.

3. Put the two rear feet 1174.0024.00 (480) on the instrument and fasten it.



3.3.6 Replacing the EMC Panel

3.3.6.1 Removing the EMC Panel

1. Removing the case (see page 87).
2. Unfasten the six screws 1148.2752.00 (290), lift up the EMC panel 1416.0886.00 (280) and remove it backwards.

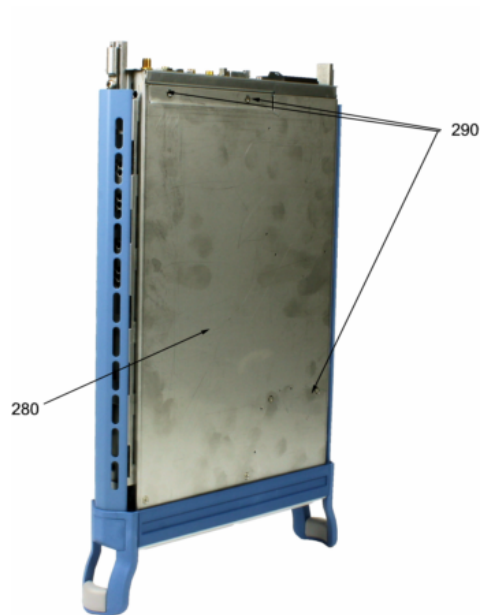

3.3.6.2 Installing the EMC Panel

1. Push the EMC panel 1416.0886.00 (280) forward and push it down. Fasten it with the six screws 1148.2752.00 (290).



2. Installing the case (see page 88).

3.3.7 Replacing the Power Supply (A50)

3.3.7.1 Removing the Power Supply

1. Switch off the instrument.
2. Remove the case (see page 87).
3. Remove the EMC panel (see page 89).
4. Disconnect the side panel 1174.1172.00 (450) by pushing it backwards and removing it from the unit.

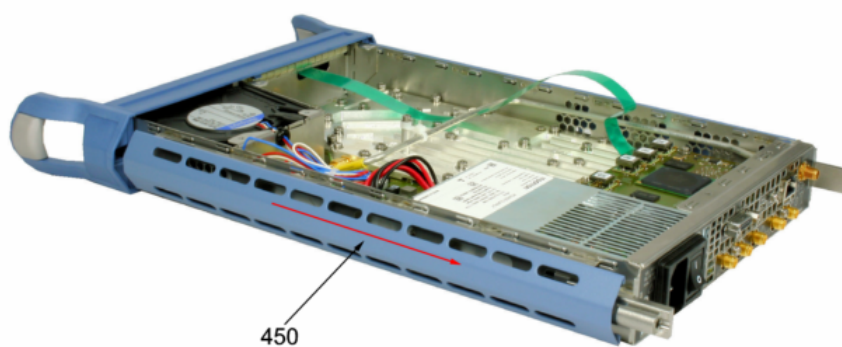

5. Unfasten the two combination screws 1148.3059.00 (60) on the rear of the instrument.

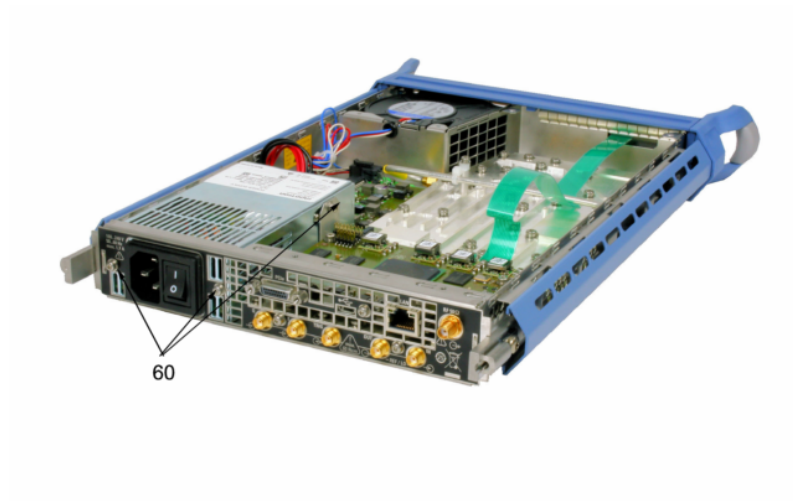

6. Unfasten the combination screws 1148.3059.00 (60) on the right and on the left of the power supply.

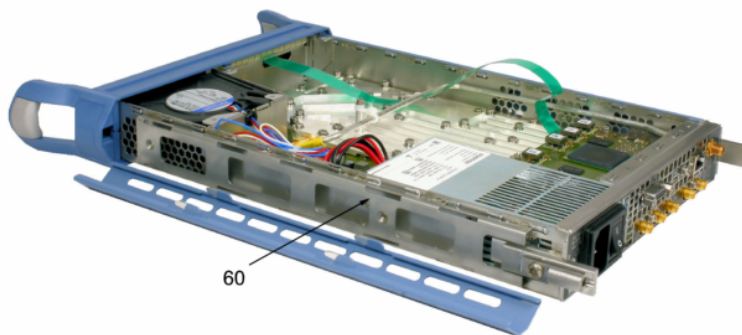

7. Disconnect the power supply cable from X270 on the RF mainboard 1416.1001.02/03 (1010/1020).
8. Lift up and remove the power supply 1416.0870.00 (50).

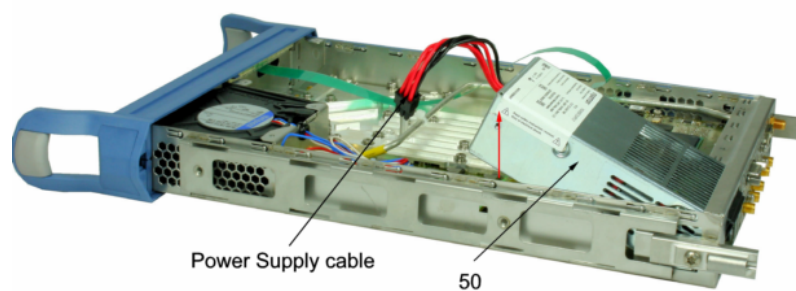

3.3.7.2 Installing the Power Supply (A50)

1. Place the power supply 1416.0870.00 (50) into the unit.
2. Connect the power supply cable on X270 on the RF mainboard 1416.1001.02/03 (1010/1020).

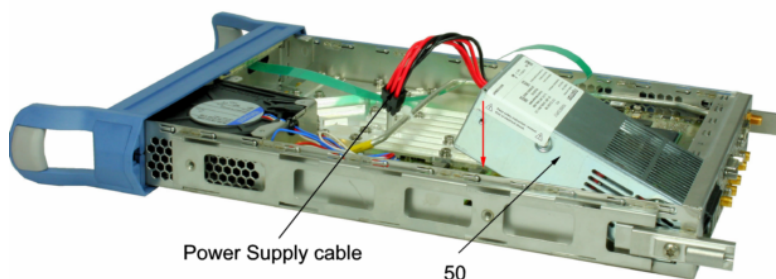

3. Fasten the two combination screws 1148.3059.00 (60) on the right and on the left of the power supply.

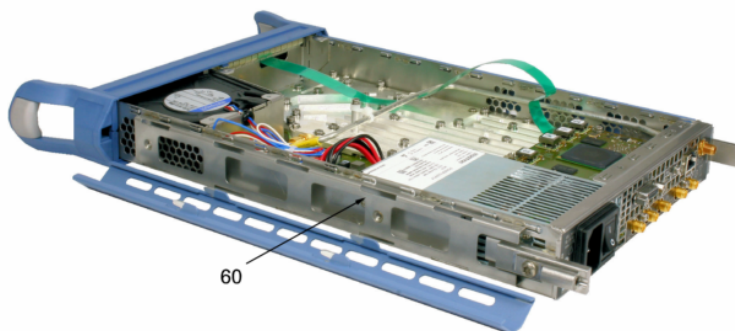

4. Connect the side panel 1174.1172.00 (450) by putting the holders of the side panel into the slots on the unit and then push it forward.

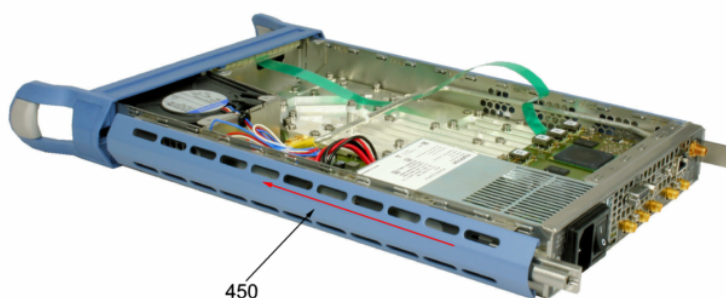

5. Fasten the two combination screws 1148.3059.00 (60) on the rear of the instrument.



6. Install the EMC panel (see page 89).
7. Install the case (see page 88).
8. Perform the necessary action described in chapter Adjustment (page 46).

3.3.8 Replacing the RF Mainboard (A200)

3.3.8.1 Removing the RF Mainboard

1. Remove the case (see page 87).
2. Remove the EMC panel (see page 89).
3. Remove the front unit (see page 100)
4. If a Doubler Board is installed on the RF mainboard, remove the front unit first. (see page 102)
5. Unfasten the three combination screws 1148.3059.00 (230 and 1050) on the rear of the instrument.
6. Unfasten the two locking screws from the controller board 1416.1201.02 (210) on the rear of the instrument.

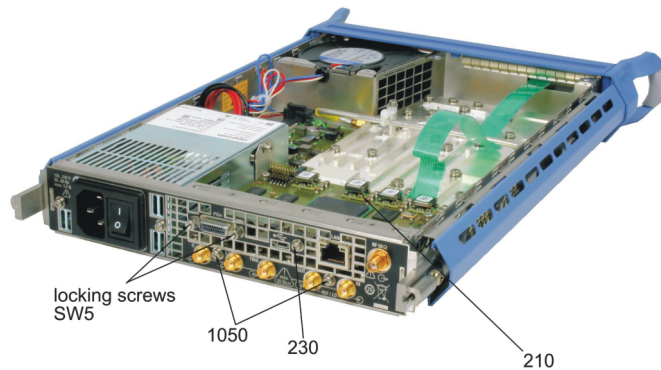

7. Unfasten the one combination screw 0041.1653.00 (1060).
8. Unfasten the one combination screw 3584.5502.00 (1140) and remove it together with the distance sleeve 1416.1099.00 (1120).
9. Unfasten the three combination screws 1096.5205.00 (1040).
10. Disconnect the fan cable from X240 and the power supply cable from X270.
11. Disconnect the flex switch board cable 1416.0640.00 (150) from X106 on the controller board 1416.1201.02 (210) carefully.

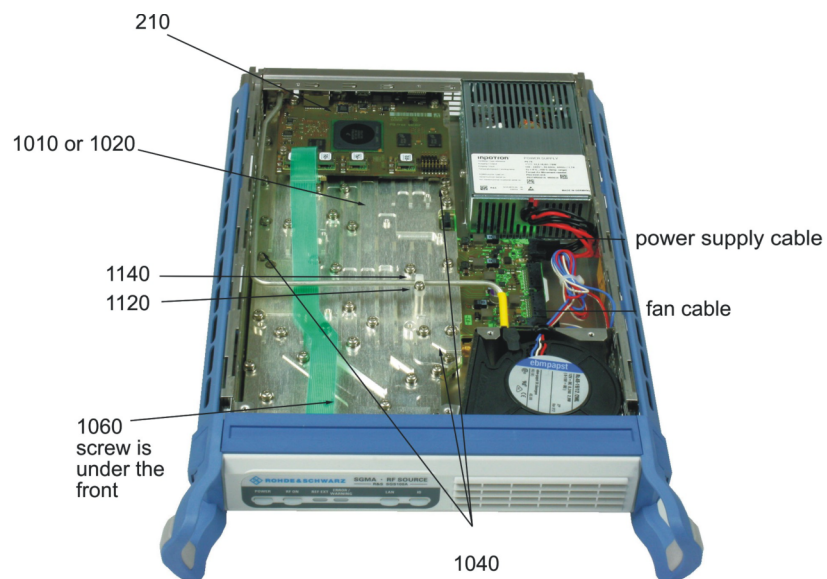

12. Lift up the RF mainboard 1416.1001.02/03 (1010/1020) and pull it in toward the front to remove it completely with the controller board 1416.1201.02 (210). If a Doubler Board is installed on the RF mainboard, remove the front unit first (see page 102).

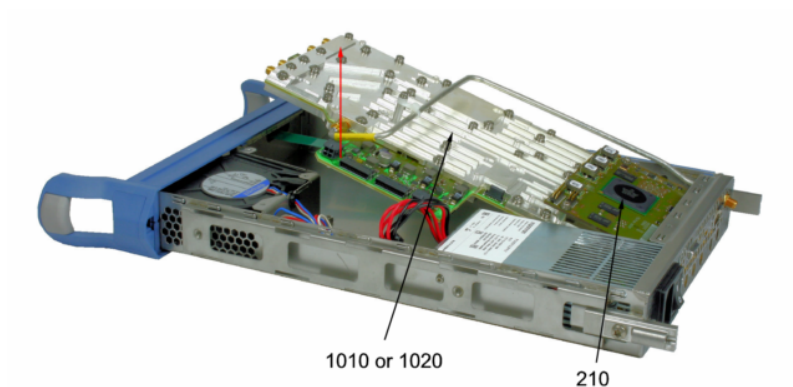

13. Unfasten the three combination screws 1096.5205.00 (260) and remove the controller board 1416.1201.02 (210).

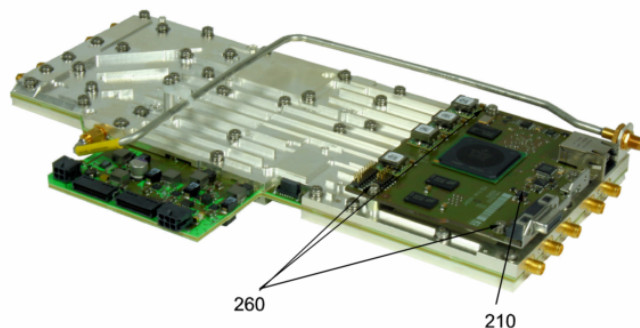

14. Unfasten the two combination screws 1148.3059.00 (1080) and disconnect the cable W100 1416.0928.00 (1100) incl. the mounting bracket 1416.0986.00 (1070).

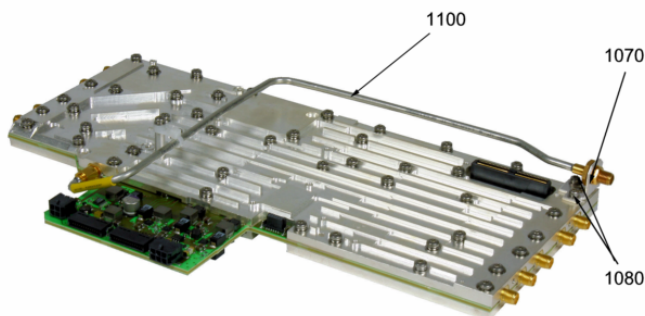

3.3.8.2 Installing the RF Mainboard (A200)

1. Fasten the cable W100 1416.0928.00 (1100) incl. the mounting bracket 1416.0986.00 (1070) with the two combination screws 1148.3059.00 (1080) on the RF mainboard 1416.1001.02/03 (1010/1020).

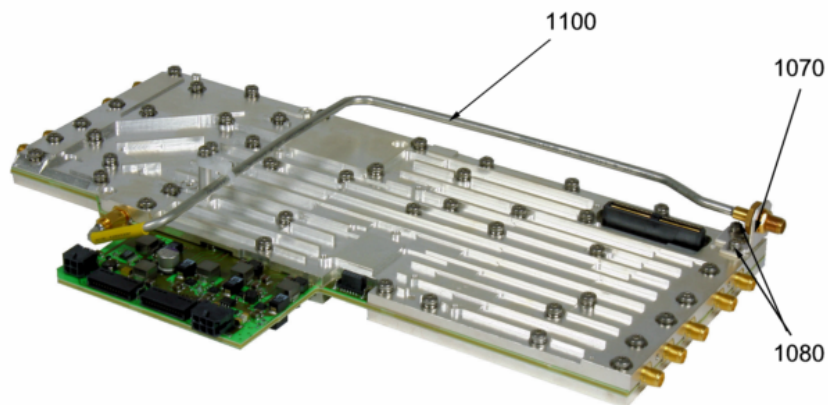

- Place the controller board 1416.1201.02 (210) on the RF mainboard and fasten it with the three combination screws 1096.5205.00 (260).

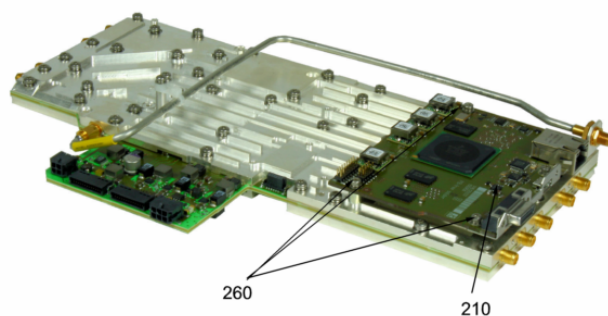

- Place the RF mainboard 1416.1001.02/03 (1010/1020), with the controller board 1416.1201.02 (210) pointing forward, into the unit and insert it carefully. If a Doubler Board is installed on the RF mainboard, remove the front unit first. (see page 102)

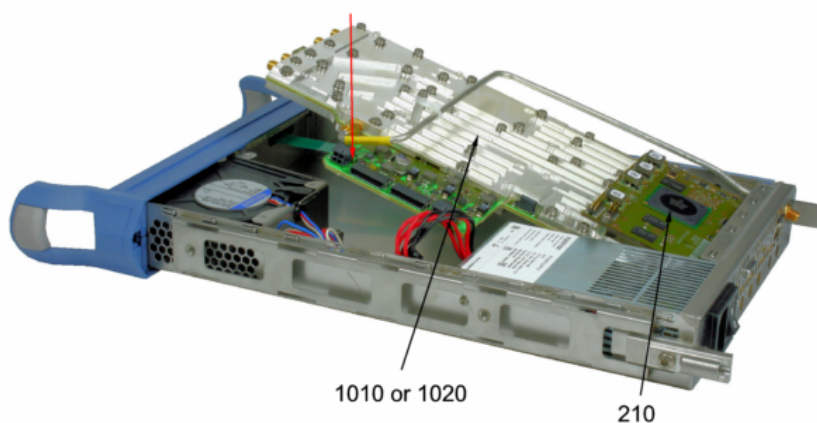

- Connect the fan cable on X240 and the power supply cable on X270.
- Connect the flex switch board cable 1416.0640.00 (150) at X106 on the controller board 1416.1201.02 (210) carefully.
- Fasten the three combination screws 1096.5205.00 (1040).

7. Fasten the combination screw 3584.5502.00 (1140) together with the distance sleeve 1416.1099.00 (1120).
8. Fasten the one combination screw 0041.1653.00 (1060).

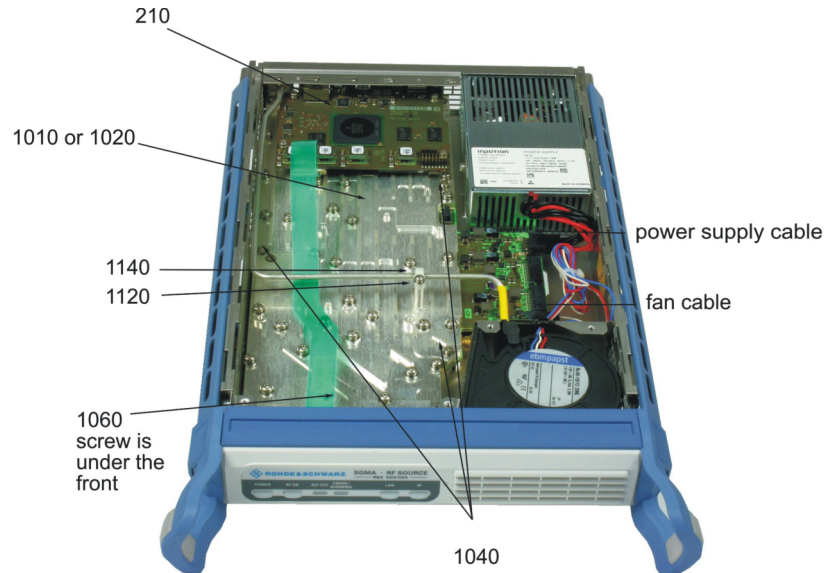

9. Fasten the three combination screws 1148.3059.00 (230 and 1050) on the rear of the instrument.
10. Fasten the two locking screws on the controller board 1416.1201.02 (210) on the rear of the instrument.

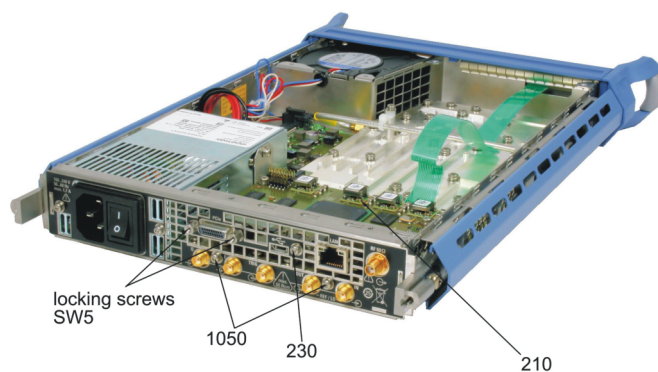

11. Install the EMC panel (see page 89).
12. Install the case (see page 88).
13. Perform the necessary action described in chapter Adjustment (page 46).

3.3.9 Replacing the Controller Board A100

The controller board 1416.1201.02 (210) is located on the RF mainboard.

To remove it, refer to [Removing the RF Mainboard](#).

3.3.9.1 Removing the Controller

1. Remove the case (see page 87).
2. Remove the EMC panel (see page 89).
3. Unfasten the three combination screws 1148.3059.00 (230 and 1050) on the rear of the instrument.
4. Unfasten the two locking screws from the controller 1416.1201.02 (210) on the rear of the instrument.

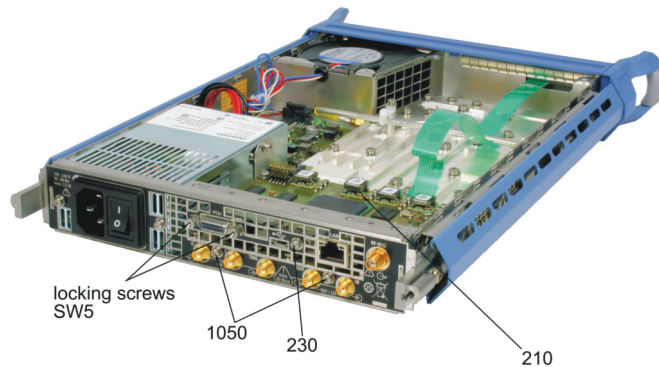

5. Unfasten the combination screw 0041.1653.00 (1060).
6. Unfasten the combination screw 3584.5502.00 (1140) and remove it together with the distance sleeve 1416.1099.00 (1120).
7. Unfasten the three combination screws 1096.5205.00 (1040).
8. Disconnect the fan cable from X240 and the power supply cable from X270.
9. Disconnect the flex switch board cable 1416.0640.00 (150) from the controller board 1416.1201.02 (210) carefully.

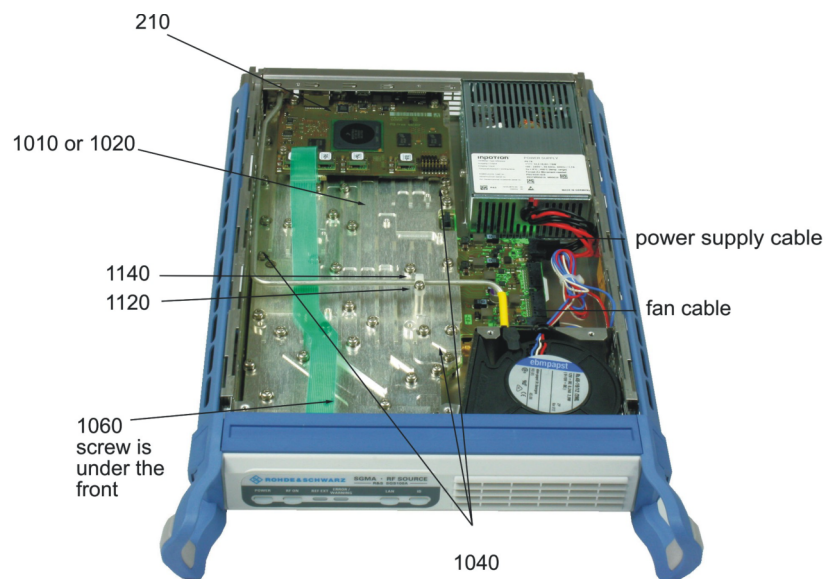

10. Lift up the RF mainboard 1416.1001.02/03 (1010/1020) and pull it towards the front to remove it completely with the controller 1416.1201.02 (210). If a Doubler Board is installed on the RF mainboard, remove the front unit first. (see page 102)

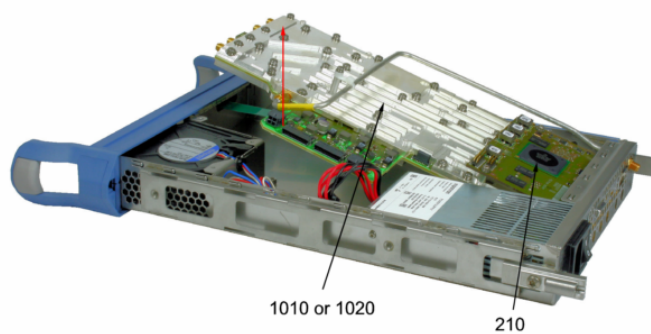

11. Unfasten the three combination screws 1096.5205.00 (260) and remove the controller 1416.1201.02 (210).

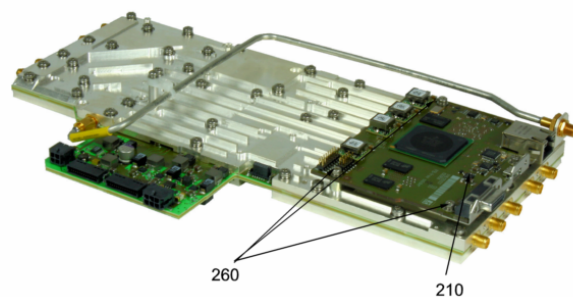

3.3.9.2 Installing the Controller (A100)

1. Make sure the correct SIM card is attached to the controller board.
2. Place the controller 1416.1201.02 (210) on the RF mainboard and fasten it with the three combination screws 1096.5205.00 (260).

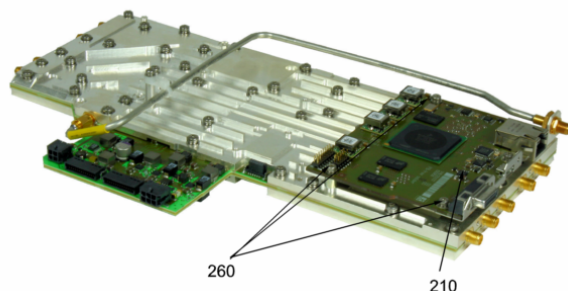

3. Place the RF mainboard 1416.1001.02/03 (1010/1020), with the controller board 1416.1201.02 (210) pointing forward, into the unit and insert it carefully. If a Doubler Board is installed on the RF mainboard, remove the front unit first. (see page 102)

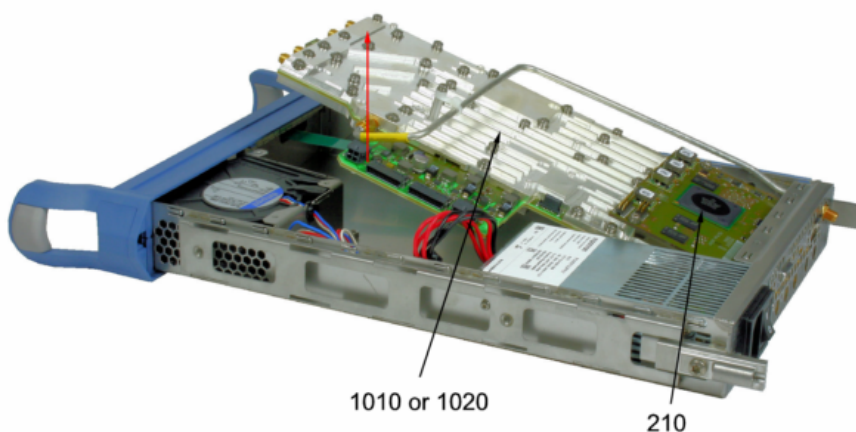

4. Connect the fan cable on X240 and the power supply cable on X270.
5. Connect the flex switch board cable 1416.0640.00 (150) on X106 on the controller board 1416.1201.02 (210) carefully.
6. Fasten the three combination screws 1096.5205.00 (1040).
7. Fasten the combination screw 3584.5502.00 (1140) together with the distance sleeve 1416.1099.00 (1120).
8. Fasten the combination screw 0041.1653.00 (1060).

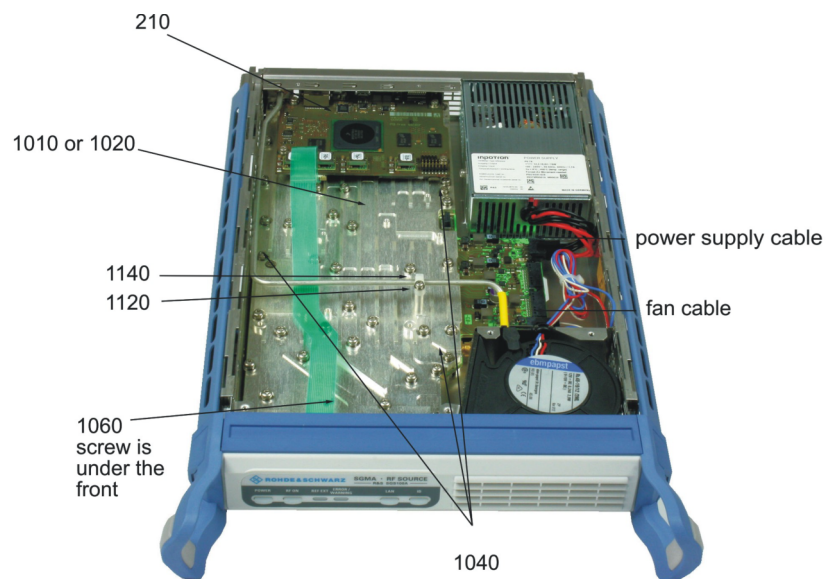

9. Fasten the three combination screws 1148.3059.00 (230 and 1050) on the rear of the instrument.
10. Fasten the two locking screws on the controller 1416.1201.02 (210) on the rear of the instrument.

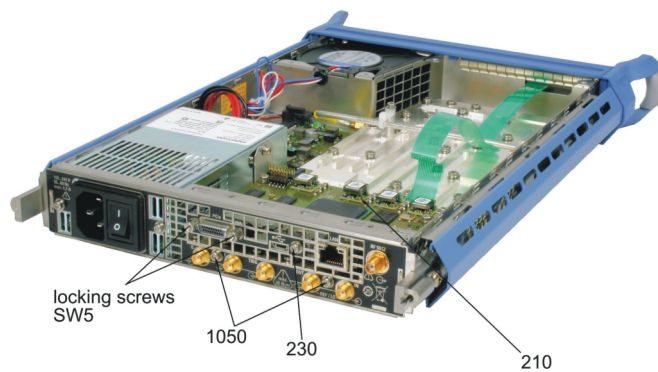

11. Install the EMC panel (see page 89).
12. Install the case (see page 88).
13. Perform the necessary action described in chapter Adjustment (page 46).

3.3.9.3 Replacing the SIM Card

NOTICE

If you replace the controller, you have to remove the SIM card.

The SIM card is part of your instrument and will not be replaced by Rohde & Schwarz if it becomes lost. Always keep the SIM card with you.

1. Remove the controller (see page 98).
The SIM card 3555.0687.00 (220) is located on the bottom of the controller (210).
2. Open the latch of the SIM card holder by sliding the retaining bracket toward OPEN.

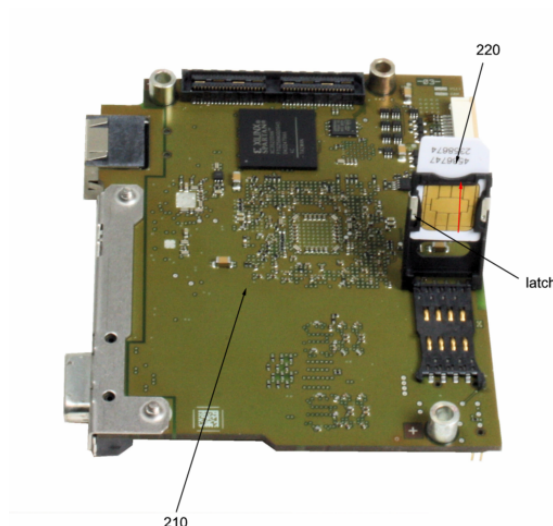

3. Flip up the SIM card holder and remove the SIM card 3555.0687.00 (220).
4. To install the SIM card, proceed in the reverse order.

3.3.10 Replacing the Front Unit

3.3.10.1 Removing the Front Unit

1. Switch off the instrument.
2. Remove the case (see page 87).
3. Remove the EMC panel (see page 89).
4. Remove the grip cover 1174.0499.00 (190) on both sides of the instrument.

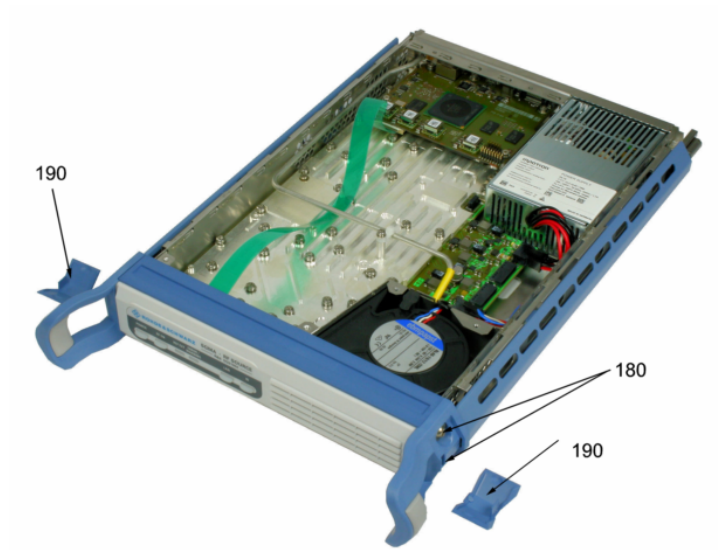

5. Unfasten the four screws 1096.4896.00 (180) and remove the two front grips 1174.0018.00 (170).

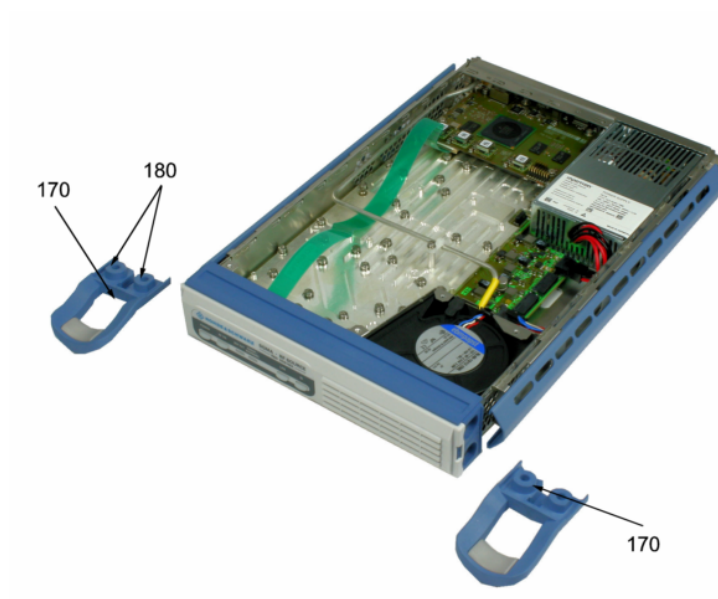

6. Disconnect the flex switch board cable 1416.0640.00 (150) from the controller board 1416.1201.02 (210) carefully.

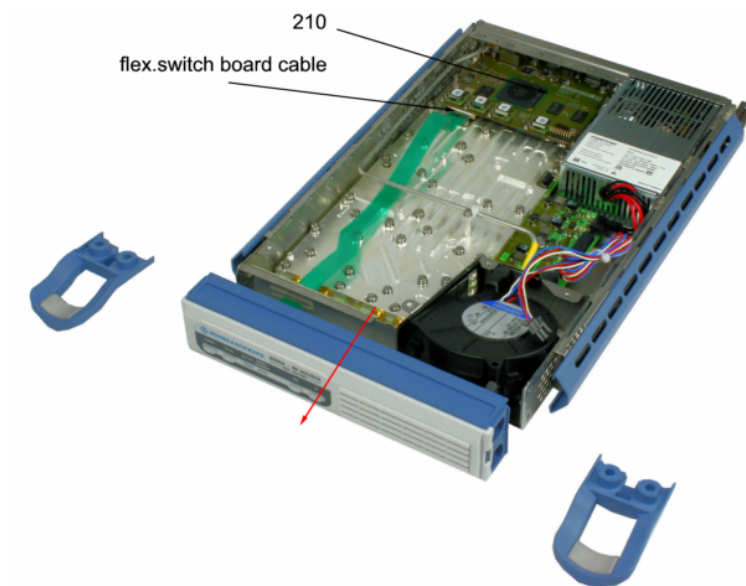

7. Pull the entire front unit forward.

3.3.11 Replacing the Flex Switch Board A300

3.3.11.1 Removing the Flex Switch Board and Push-Button Board

1. Switch off the instrument.
2. Remove the case (see page 87).
3. Remove the EMC panel (see page 89).
4. Remove the grip cover 1174.0499.00 (190) on both sides of the instrument.

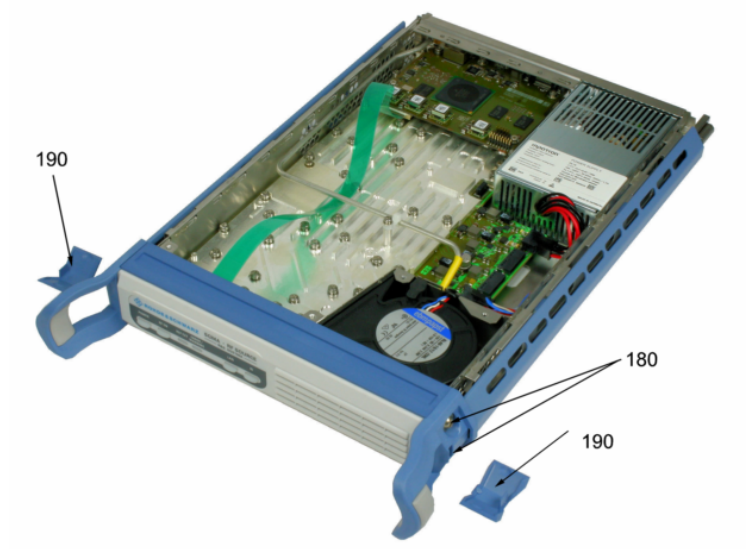

5. Unfasten the four screws 1096.4896.00 (180) and remove the two front grips 1174.0018.00 (170).

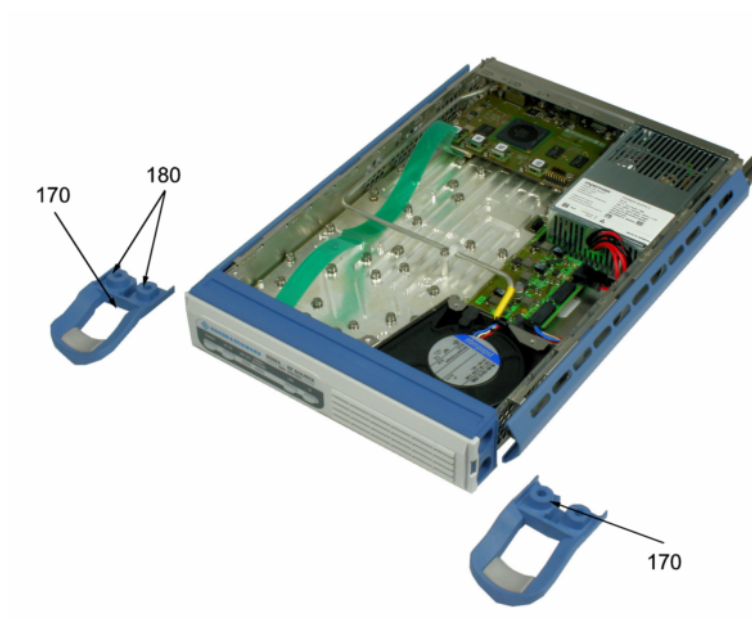

6. Disconnect the flex switch board cable 1416.0640.00 (150) from X106 on the controller 1416.1201.02 (210) carefully.

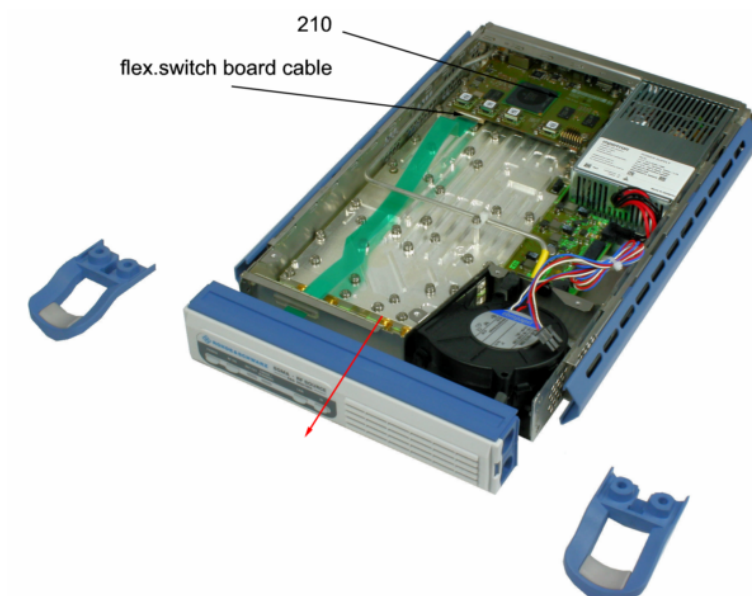

7. Pull the entire front unit forward.
8. Carefully push the five holders apart and remove the flex switch board A300 1416.0640.00 (150).

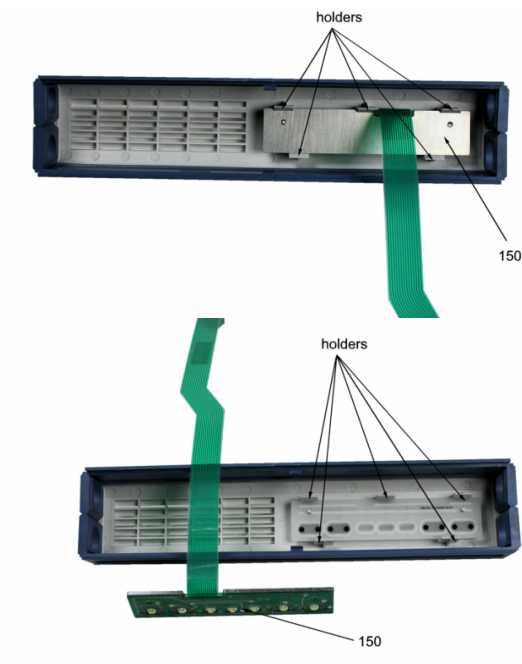

9. Remove the push-button board 1416.0628.00 (140).

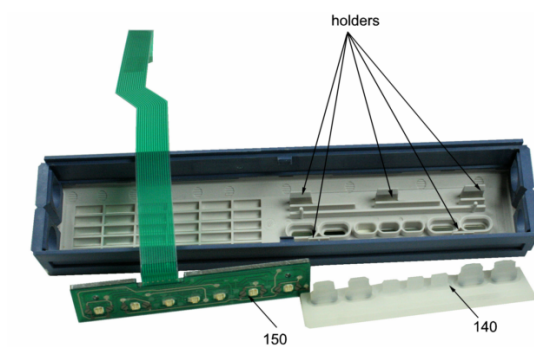

3.3.11.2 Installing the Flex Switch Board and the Push-Button Board

1. Install the push-button board 1416.0628.00 (140).

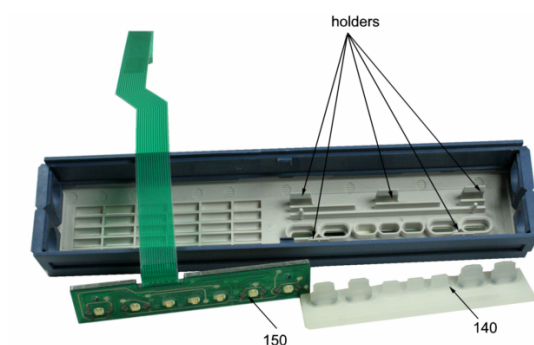

2. Install the flex switch board A300 1416.0640.00 (150) and click it carefully into the five holders.

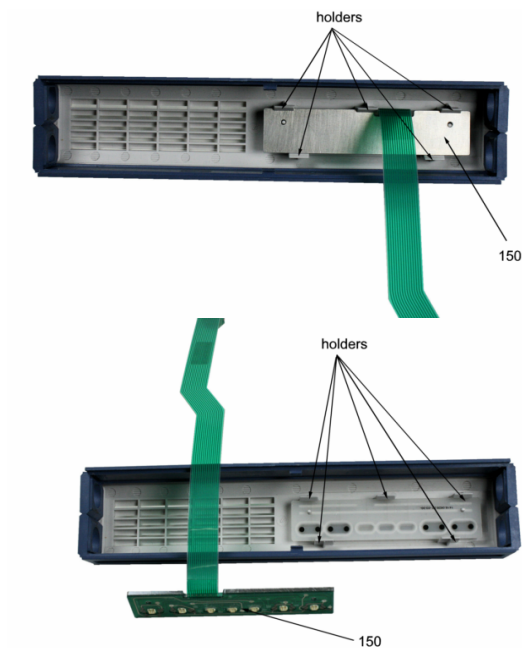

3. Push the entire front unit backward.

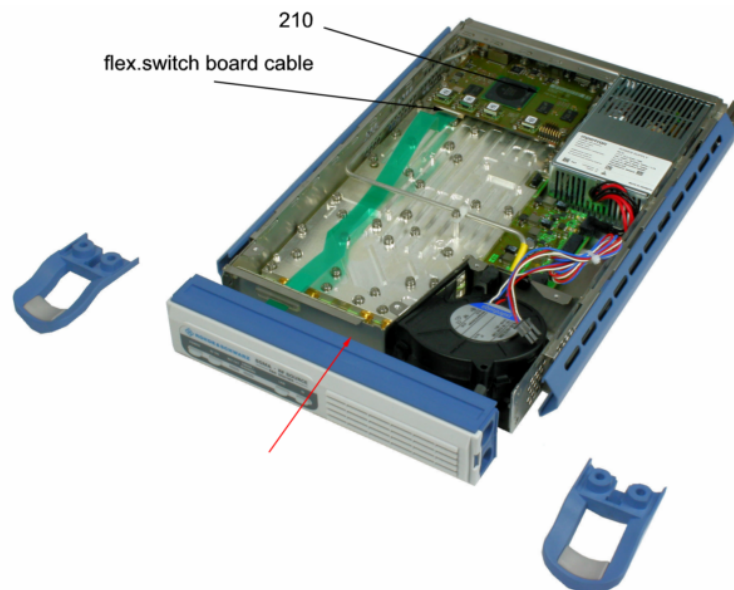

4. Connect the flex switch board cable 1416.0640.00 (150) at X106 on the controller 1416.1201.02 (210) carefully.
5. Put the two front grips 1174.0018.00 (170) back and fasten them with the four screws 1096.4896.00 (180).

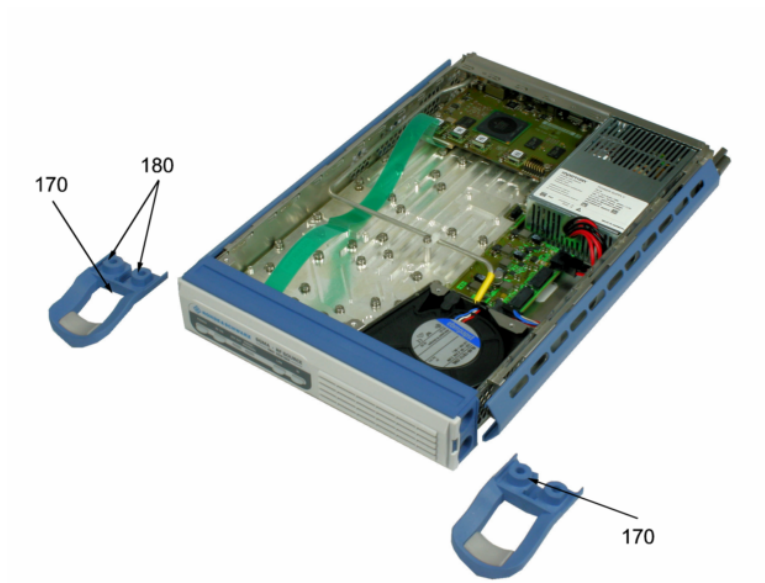

6. Put the grip cover 1174.0499.00 (190) back.

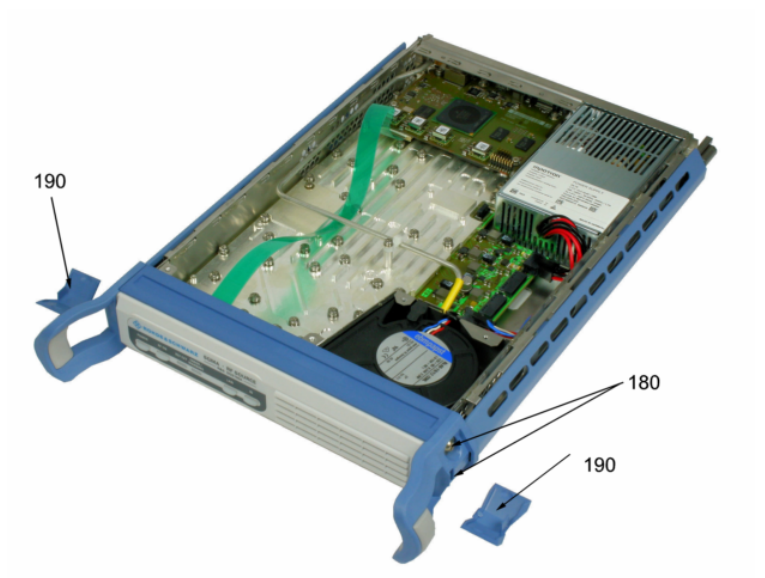

7. Install the EMC panel.
8. Install the case.

3.3.12 Replacing the Fan E1

Note: Always make sure the instrument fan operation is not constrained by dust etc.
The fan can be inspected through the air intake at the case bottom side.

1. Switch off the instrument and disconnect the main plug.
2. Remove the case (see page 87).

3. Remove the EMC panel (see page 89).
4. Remove the front unit (see page 102)
5. Disconnect the fan cable from X240 on the RF mainboard (1010 or 1020).

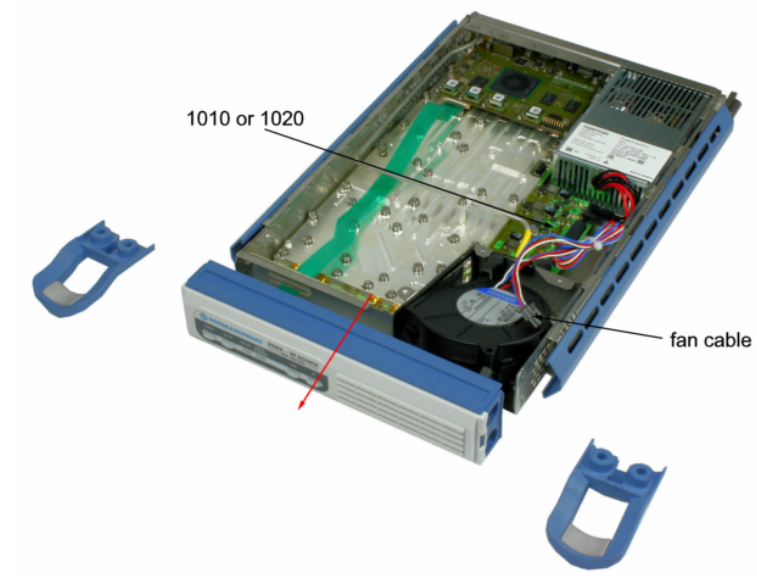

6. Lift out the fan with the two rubber clips.

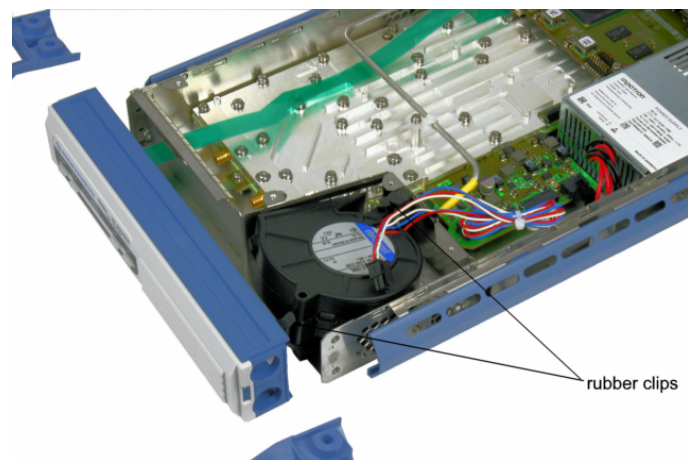

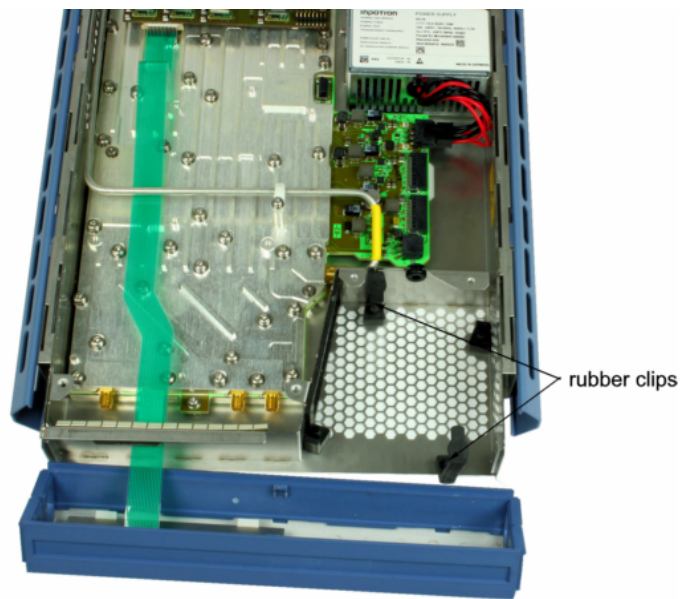

7. Install the new fan. For assembly of the instrument proceed in the reverse order.

3.3.13 Replacing the OCXO Board R&S SGS-B1

3.3.13.1 Removing the OCXO Board

1. Switch off the instrument and disconnect the main plug.
2. Remove the case (see page 87).
3. Remove the EMC panel (see page 89).
4. Unfasten the two combination screws (1830) and carefully remove the OCXO board 1416.2508.02 (1810) from the RF mainboard 1416.1001.02/02 (1010/1020).

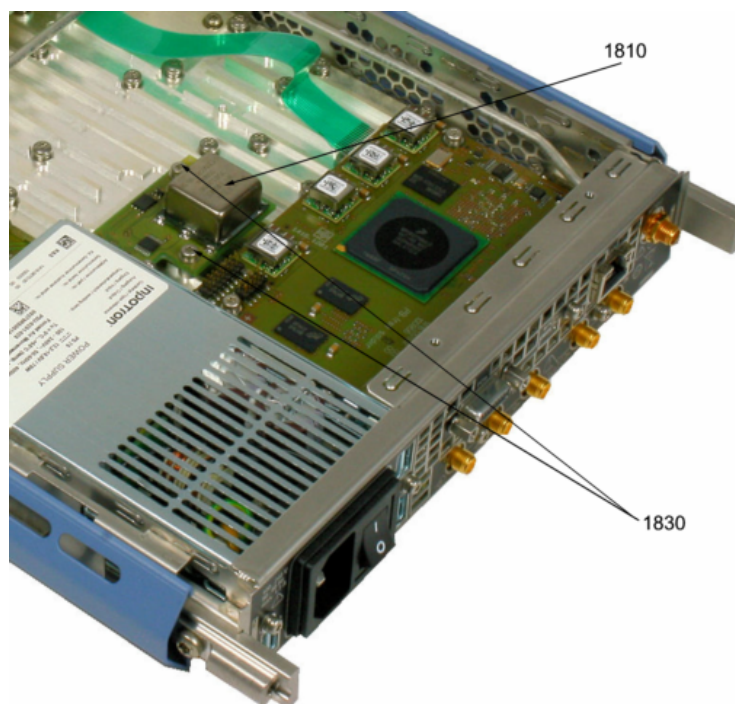

3.3.13.2 Installing the OCXO Board

1. Switch off the instrument and disconnect the main plug.
2. Remove the case (see page 87).
3. Remove the EMC panel (see page 89).
4. Carefully place the OCXO Board 1416.2508.02 (1810) on the RF mainboard 1416.1001.02/03 (1010/1020) and fasten it with two combinations screws (1830).
5. Install the EMC panel (see page 89).
6. Install the case (see page 88).
7. Perform the necessary action described in chapter Adjustment (page 46).

3.3.14 Replacing the Doubler Board - R&S SGS-B112/-B112V (A400)

3.3.14.1 Removing the Doubler Board

1. Switch off the instrument and disconnect the main plug
2. Remove the case (see page 82).
3. Remove the EMC panel (see page 84).
4. Remove the front unit (see page 99).
5. Unfasten the two locking screws on the controller board 1416.1201.02 (210) on the rear of the instrument.

6. Unfasten the three combination screws 1148.3059.00 (230 and 1050) on the rear of the instrument.
7. Unfasten the combination screw 0041.1653.00 (1060)
8. Unfasten the three combination screws 1096.5205.00 (1040)
9. Carefully disconnect the flex switch board cable 1416.0640.00 (150) on the controller board 1416.1201.02 (210)
10. Disconnect the fan cable on X240 and the power supply cable on X270.
11. Lift up the RF mainboard 1416.1001 and pull it towards the front to remove it completely with the doubler board 1416.1601.02 (1310) and controller 1416.1201.02 (210).
12. Disconnect the ribbon cable W206 1416.1524.00 (1650) at X405 on Doubler Board 1416.1601 and at X211 on the RF mainboard.
13. Disconnect the four RF cables connecting the RF mainboard 1416.1001.03 (1010) with the doubler board 1416.1601.02/03 (1310/1320). First W210 1416.1747 (1400), then W209 1416.1747.00 (1400), then W207 1416.1724.00 (1380) and W208 1416.1730.00 (1390).

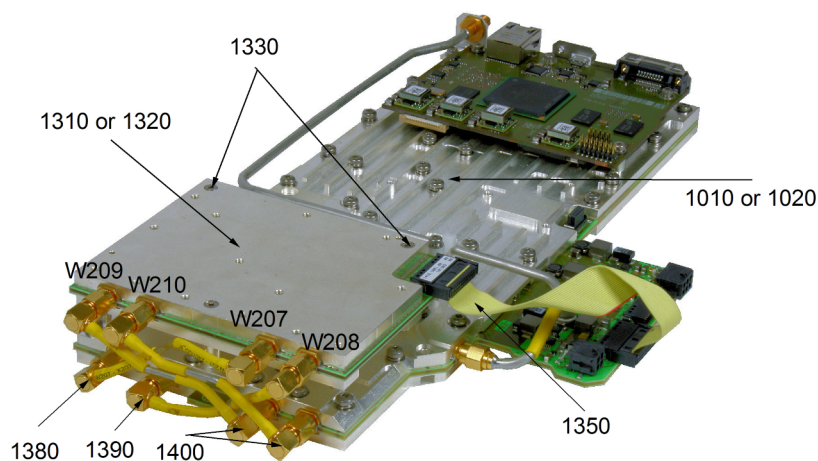

14. Unfasten the three screws 1416.1547.00 (1330) and remove the Doubler Board from the RF mainboard.

3.3.14.2 Installing the Doubler Board

NOTICE

The Doubler Board 1416.1601.02 is the R&S SGS-B112 option (1310) and can be installed in units with the RF mainboard 1416.1001.03 (1010).

The Doubler Board 1416.1601.03 is the R&S SGS-B112V option (1320) and can be installed in units with the RF mainboard 1416.1001.02 (1020) with revision number greater or equal to 6.09.

Note: Instruments with serial numbers lower than 101600 can not be upgraded with the R&S SGS-B112V option due to the installed RF mainboard version.

CAUTION

Risk of shock hazard and instrument damage

When replacing the electronic step attenuator and/or the doubler board be aware of connecting the ribbon cables (W206/W221) with the right connector of the RF mainboard.

1. Switch off the instrument and disconnect the main plug.
2. Remove the case (see page 87).
3. Remove the EMC panel (see page 89).
4. Remove the RF mainboard (see page 93).
5. Connect the RF cables on the RF mainboard 1416.1001.03 (1010). First W207 14161724.00 (1380) on the left side, then W208 1416.1730.00 (1390), then W209 1416.1747.00 (1400) and W210 1416.1747.00 (1400) on the right side.

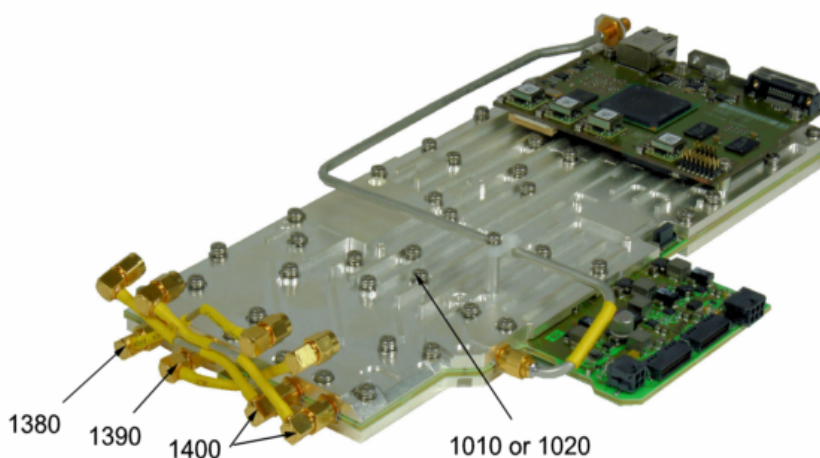

6. Place the Doubler Board 1416.1601.02 (1310) on the RF mainboard and connect the four RF cables. First W207 1416.1724.00 (1380) on the left side, then W208 1416.1730.00 (1390), then W209 1416.1747.00 (1400) and W210 1416.1747.00 (1400) on the right side.
7. Fasten the Doubler Board on the RF mainboard with the three screws 1416.1547.00 (1330).
8. Connect the ribbon cable W211 1416.1524.00 (1350) at X405 on Doubler Board 1416.1601.02/03 (1310/1320) and at X211 on RF mainboard 1416.1001.03 (1010).

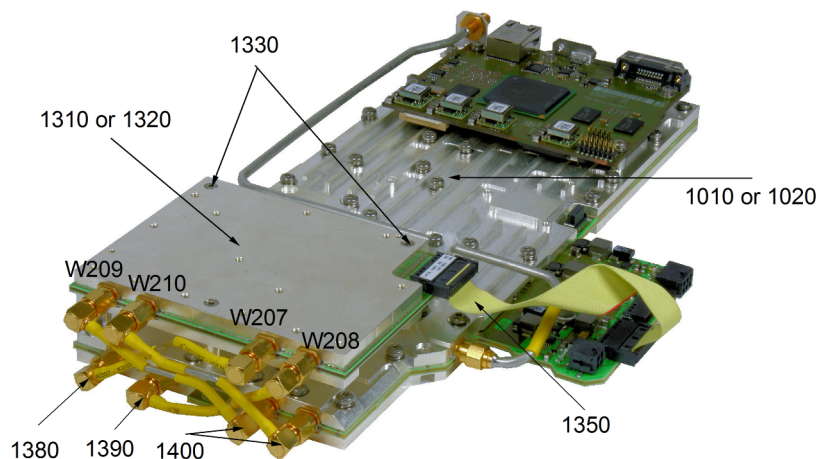

9. Carefully insert the RF mainboard with the controller board 1416.1201.02 (210) and the doubler board option into the unit.
10. Connect the fan cable on X240 and the power supply cable on X270.
11. Connect the flex switch board cable 1416.0640.00 (150) on the controller board 1416.1201.02 (210) carefully.
12. Fasten the three combination screws 1096.5205.00 (1040).
13. Fasten the combination screw 0041.1653.00 (1060).

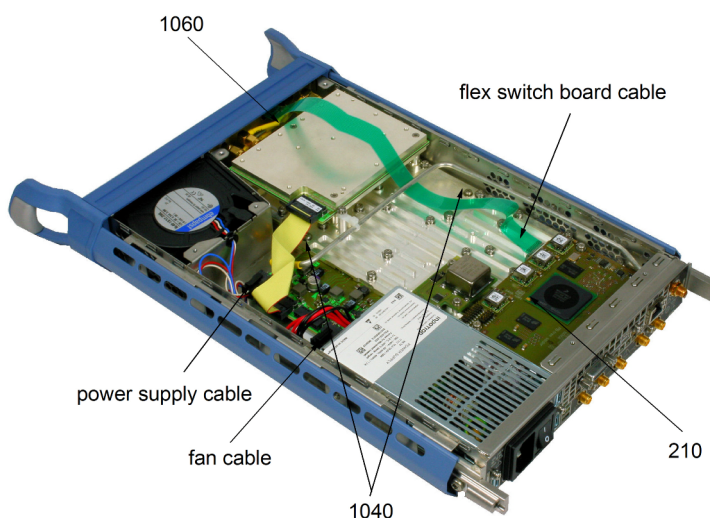

14. Fasten the combination screw 0041.1653.00 (1060).
15. Fasten the two locking screws on the controller 1416.1201.02 (210) on the rear of the instrument.
16. Install the EMC panel (see page 89).
17. Install the case (see page 88).
18. Perform the necessary action described in chapter Adjustment (page 46).

3.3.15 Replacing the Electronic Step Attenuator R&S SGS-B26)

3.3.15.1 Removing the Electronic Step Attenuator

1. Switch off the instrument and disconnect the main plug.
2. Remove the case (see page 85).
3. Remove the EMC panel (see page 87).
4. Remove the RF mainboard (see page 93).
5. Disconnect the RF cable W110A 1416.1501.00 (1680) on X220 on the Step Attenuator, the RF cable W100A 1416.1499.00 (1690) on X221 and the ribbon cable W206 1416.1524.00 (1650) on X700.
6. Unfasten the four screws 1416.1545.00 (1610) and remove the attenuator board.

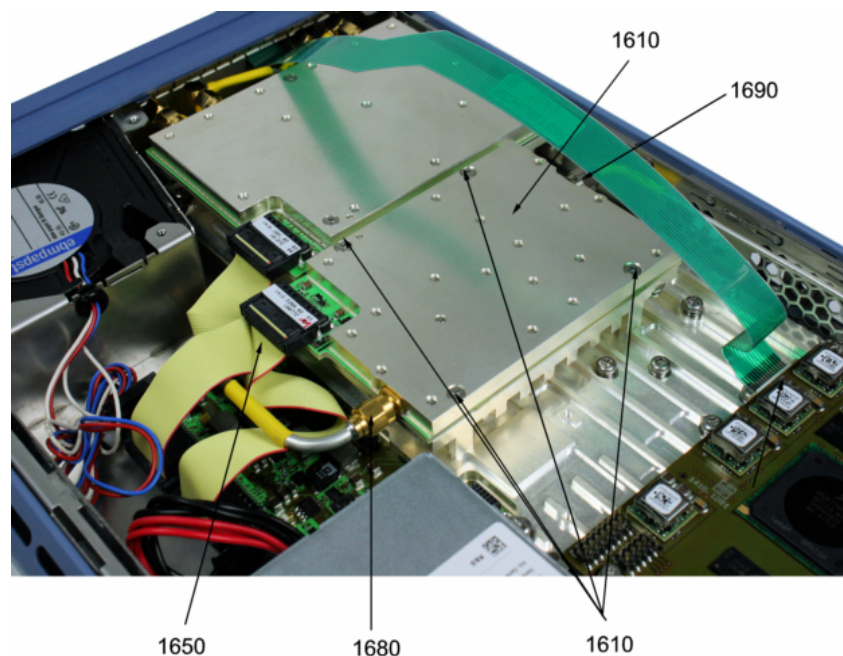

3.3.15.2 Installing the Electronic Step Attenuator

CAUTION

Risk of shock hazard and instrument damage

When replacing the electronic step attenuator and/or the doubler board be aware of connecting the ribbon cables (W206/W221) with the right connector of the RF mainboard.

1. Switch off the instrument and disconnect the main plug.
2. Remove the case (see page 87).
3. Remove the EMC panel (see page 89).
4. Remove the RF mainboard (see page 93).
5. Disconnect the cable W100 1416.0928.00 (1100) from the RF mainboard 1416.1001.02/03 (1010/1020).
6. Unfasten the combination screw 3584.5502.00 (1140) and the distance sleeve 1416.1099.00 (1120).
7. Unfasten the nut incl. the lock washer from the cable W100 on the rear of the instrument and remove the cable.

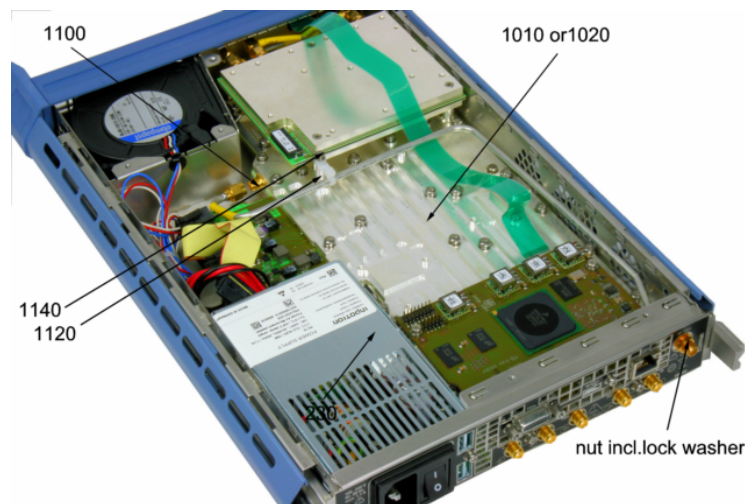

8. Connect the RF cable W110A 1416.1501.00 (1680) on the RF mainboard 1416.1001.02/03 (1020/1010).
9. Install the new RF cable W100A 1416.1499.00 (1690) on the rear of the instrument, put the lock washer on and fasten the nut.
10. Connect the ribbon cable W206 1416.1524.00 (1650) on X206 of the RF mainboard 1416.1001.02/03 (1010/1020).

Module Replacement and Upgrade

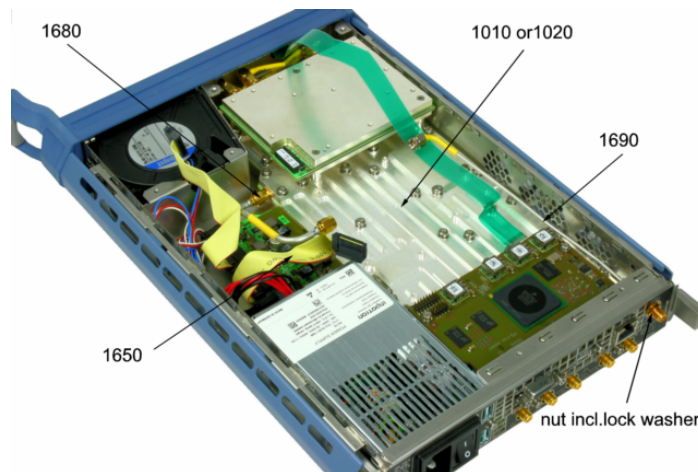

11. Place the Step Attenuator 1412.5360.02 (1610) on the RF mainboard 1416.1001.02/03 (1010/1020) and connect it with the four screws 1416.1547.00 (1630).
12. Connect the RF cable W110A 1416.1501.00 (1680) on X501 on the Step Attenuator, the new RF cable W100A 1416.1499.00 (1690) on X502 and the ribbon cable W206 1416.1524.00 (1650) on X503.

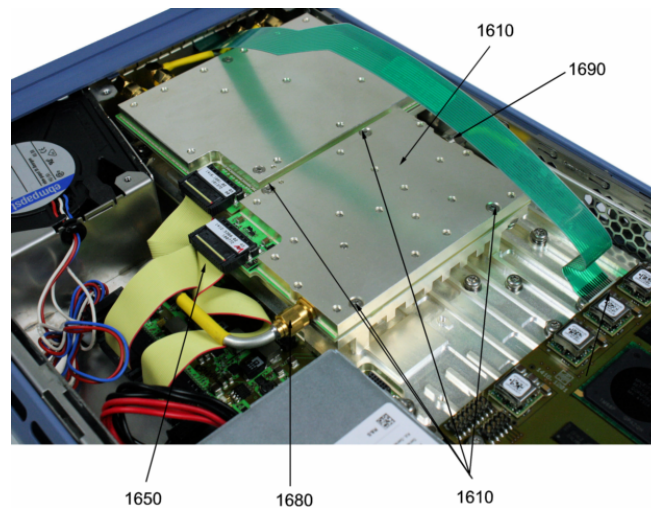

13. Install the RF mainboard
14. Install the EMC panel (see page 89).
15. Install the case (see page 88).
16. Perform the necessary action described in chapter Adjustment (page 46).

4 Firmware Update

1. Select "SGMA-GUI main panel > Instrument Name > Setup > Maintenance > Operation > Install firmware package".
2. Press "Select Package" and navigate to the directory the new firmware is stored in.
3. Enter the "Security Password".
4. Confirm the update with "Accept".
The software transfers the firmware file and automatically starts the update procedure. During the update, the message "Updating Firmware" is displayed in the Info line.
Note: *The update procedure requires restart of the instrument. The restart is performed automatically. The instrument is not accessible during that time.*
5. Wait until the message "Updating Firmware" disappears and the update is completed. The green POWER ON/STANDBY LED is on.
Tip: *Calibration Error. If the Info line shows the message "Calibration Error", select "SGMA-GUI main panel > Instrument Name > Setup > Internal Adjustments > Adjust All" to trigger internal adjustment.*
6. If required, install the new R&S SGMA-GUI.
For detailed description, refer to the Getting Started guide, section "Installing the R&S SGMA-GUI Software on the External PC".

5 Factory Recover and USB Install

Hold down front panel buttons ID and LAN simultaneously while switching on the instrument to start factory recover or USB install.

On factory recover the instrument installs the firmware the instrument was originally shipped with. This firmware resides in a special partition in the instrument's persistent memory. It can be erased using function "Erase factory recover partition" on dialog Maintenance (protection level 3 required).

Besides installing the original firmware factory recover also clears the internal memory restoring the instrument to its original state (Instrument Sanitize function).

If a USB stick with a firmware package (*.rsu file) is found the firmware package on the USB stick is used instead of the contents of the recovery partition.

The progress of the installation procedure is signaled by a running light on the front panel. When it is finished the lights stop and the LEDs now indicate the status. All LEDs green: success. All LEDs red except one LED orange: failure.

The position of the one orange LED indicates the reason for the failure.

- 1st (leftmost) LED: Cannot access recovery partition or USB stick
- 2nd LED: No update package or recovery package found.
- 3rd LED: Update package or recovery package defective.
- 4th LED: System partition defective.
- 5th LED: Out of flash memory
- 6th LED: Update package defective
- 7th LED: Flash memory write error

The LEDs stay on for 1 minute after which the instrument performs an automatic reboot.

6 Documents

6.1 Spare Parts

The stock numbers necessary for ordering replacement parts and modules can be found in the spare part list further down.

⚠ CAUTION

Risk of shock hazard and instrument damage

When replacing a module please note the safety instructions and the repair instructions given in chapter 3 and at the beginning of this service manual.

When shipping a module be careful to provide for sufficient mechanical and antistatic protection.

6.1.1 Available Power Cables

Stock No	Earthed-contact connector	Preferably used in
DS 0006.7013.00	S1363: 1967' 10 A, 250 V complying with IEC 83: 1975 standard B2	Great Britain
DS 0006.7020.00	Type 12, 10 A, 250 V complying with SEV-regulation 1011.1059, standard sheet S 24 507	Switzerland
DS 0006.7036.00	Type 498/13, 10 A, 250 V complying with US-regulation UL 498, or with IEC 83	USA/Canada
DS 0041.4752.00	GB2099, GB1002, 10 A, 250 V approvals CCC	China
DS 0041.6232.00	JIS C 8303, 7A, 125 V AC approvals PSE (JET)	Japan
DS 0006.7107.00	Type SAA3, 10 A, 250 V, complying with AS C112-1964 Ap.	Australia
DS 0025.2365.00 DS 0099.1456.00	DIN 49 441, 10 A, 250 V, angular DIN 49 441, 10 A, 250 V, straight approvals VDE, ÖVE, CEPEC, KEMA, S, D, N, FI, LCIE, IMQ, UCIEEEurope	Europe (except Switzerland)

6.2 Spare Part List and Mechanical Drawings

Für diese Unterlage behalten wir uns alle Rechte vor.
 Ausgedruckte Dokumente unterliegen nicht dem Änderungsdienst.
 For this document all rights are reserved.
 Printed documents are not subject to revision

el.Kennz <i>Part</i>	Benennung / Hinweise <i>Designation</i>	Sachnummer <i>Stock No.</i>	Hersteller <i>Manufacturer</i>	Bestellbezeichnung <i>Designation</i>	enthalten in <i>contained in</i>
	ACHTUNG EGB /ATTENTION ESD *VARIANTENERKLAERUNG *EXPLANATION OF MODELS VAR02=GRUNDVARIANTE MOD02=BASIC MODEL				
A50	NJ NETZTEIL PS75 POWER SUPPLY UNIT PS75	1416.0870.00	INPOTRON	PSU-0251-02 TAZ 06.00	1416.0505.01
A100	ED CONTROLLER BOARD CONTROLLER BOARD	1416.1201.02			1416.0505.01
A300	SF SCHALTFOLIE SGMA FLEX. SWITCH BOARD SGMA	1416.0640.00	SCHURTER	R&S-ZCHNG.1416.0640.00 AEI 05	1416.0505.01
E1	EV LUEFTER 6.1L/S 12VDC FAN 12VDC	3584.3900.00	PAPST	PAPST-ZCHNG.959220712 AEZ.B	1416.0505.01

	Benennung/Designation SGS100A SGMA RF SOURCE BASE UNIT SGS100A SGMA RF SOURCE BASE UNIT			Sprach./Lang de en	Ä.I. / C.I 12.00	Blatt/Sheet 1 of 1
	Datum/ Date 2012-04-16	Abt. / Dept. 1GPK	Name / Name HI	Dokument Nr. / Document No. 1416.0505.01 SA		

Für diese Unterlage behalten wir uns alle Rechte vor.
 Ausgedruckte Dokumente unterliegen nicht dem Änderungsdienst.
 For this document all rights are reserved.
 Printed documents are not subject to revision

Pos.-Nr. ItemNo	Menge Quantity	ME Unit	EI.Kennz Ref.Des.	Benennung / Bezeichnung Designation	Z	Sachnummer Stock No.	Ersatzteil Subst.part	BA	VH
				ACHTUNG EGB/ATTENTION ESD *VARIANTENERKLAERUNG *EXPLANATION OF MODELS VAR02=GRUNDVARIANTE MOD02=BASIC MODEL					
5	0	S		ZS ERSATZTEILLISTE VORHANDEN SPARE PARTS LIST AVAIL Sach-Nr. / Part No. 1416.0540.01 ST für SGS100A und Optionen / for SGS100A and Options		0999.9684.00		M	O
20	1	S		KB GERAETEWANNE BESCHR. HOUSING TROUGH PRINTED	Z	1416.0711.00		M	W
50	1	S	A50	NJ NETZTEIL PS75 POWER SUPPLY UNIT PS75		1416.0870.00	X	B	T
60	4	S		VS 6900/ISR-M2.5X6-A2 COMBINATION SCREWS		1148.3059.00		B	T
100	1	S	E1	EV LUEFTER 6.1L/S 12VDC FAN 12VDC		3584.3900.00	X	B	O
102	1	S		DZ KABELBI.RD 1 BIS 25 B2 CABLETIE		0015.9038.00		B	O
104	1	S		DZ HALTER KAB.BIND 4.2 HOLDER		0794.5214.00		B	O
110	2	S		EV RADIALLUEFTER-HALTERG. 27/6MM FRILL FOR FAN		1416.0970.00	X	B	O
120	1	S		DZ DURCHF.RD4XRD9.5X5.6 GROMMET		0062.1130.00		B	B
130	1	S		MM FRONTPLATTE SIGMA FRONT COVER SIGMA		1416.0828.00	X	B	B
140	1	S		SF SCHALTMATTE SIGMA RUBBER KEYPAD SIGMA		1416.0628.00	X	B	B
150	1	S	A300	SF SCHALTFOLIE SGMA FLEX. SWITCH BOARD SGMA		1416.0640.00	X	B	G
160	2	S		KN BW2010 RAHMENTEIL 1/2 BW2010 FRAME 1/2		1174.0047.00		B	T
170	2	S		KN BW2010 1E FRONTGRIFF KPL. BW2010 1U FRONT GRIP CPL. entfällt in Kombination mit SGS-B98 / not applicable in combination with SGS-B98	Z	1174.0018.00		B	O
180	4	S		VS SCHR. M4X14-ISR-PA SCREW M4X14-ISR-PA entfällt in Kombination mit SGS-B98 / not applicable in combination with SGS-B98		1096.4896.00		B	O
190	2	S		KN BW2010 1E GRIFFDECKEL BW2010 1U GRIP COVER entfällt in Kombination mit SGS-B98 / not applicable in combination with SGS-B98		1174.0499.00		B	O
210	1	S	A100	ED CONTROLLER BOARD CONTROLLER BOARD	Z	1416.1201.02	X	M	P
220	1	S		BC SMARTCARD SLE66 V4.4 SIM FORMAT SMARTCARD SLE66 V4.4 SIM FORMAT		3586.7860.00		B	I
230	1	S		VS 6900/ISR-M2.5X6-A2 COMBINATION SCREWS		1148.3059.00		B	T
260	3	S		VS HVC/ISR-M2.5X12-A2		1096.5205.00		B	B



ROHDE & SCHWARZ

Benennung/Designation

SGS100A SGMA RF SOURCE BASE UNIT
SGS100A SGMA RF SOURCE BASE UNIT

Sprach./Lang

de en

Ä.I. / C.I

12.00

Blatt/Sheet

1 of 2

Dokument Nr. / Document No.

1416.0505.01 ST

SGS100A

Datum/
Date

2012-04-16

Abt. /
Dept.

1GPK

Name /
Name

HI

Für diese Unterlage behalten wir uns alle Rechte vor.
Ausgedruckte Dokumente unterliegen nicht dem Änderungsdienst.
For this document all rights are reserved.
Printed documents are not subject to revision

Pos.-Nr. ItemNo	Menge Quantity	ME Unit	El.Kennz Ref.Des.	Benennung / Bezeichnung Designation	Z	Sachnummer Stock No.	Ersatzteil Subst.part	BA	VH
280	1	S		COMBINATION SCREWS MZ EMV-HAUBE EMV-PANEL	Z	1416.0886.00		M	P
290	6	S		VS 965/ISR-M2.5X5-A4-PA SCREW		1148.2752.00		B	T
300	1	S		HS FIRMWARE SGS100A FIRMWARE SGS100A	Z	1416.0534.00		M	P
320	1	S		OS CSA-SCHILD CSA LABEL nur verwenden, wenn Ausschnitt in Pos. 350 passend oder wenn SGS100A mit Opt. SGS- B98 bestellt wurde		1416.0957.00		M	P
325	1	S		OS CSA-SCHILD INKL. KOREA CSA LABEL INCL. KOREA nur verwenden, wenn Ausschnitt in Pos. 350 passend ist oder wenn SGS100A mit Opt. SGS-B98 bestellt wurde		1416.0605.00		M	P
350	1	S		ZN BW2010 1E 1/2 T350 ABD. UNTEN PERF BW2010 1E 1/2 T350 COVER LOWER entfällt in Kombination mit SGS-B98 / not applicable in combination with SGS-B98	Z	1416.0911.00		M	B
360	4	S		KN BW2010 GERAETEFUSS 12MM KOMPL. BW2010 FOOT 12MM KOMPL. entfällt in Kombination mit SGS-B98 / not applicable in combination with SGS-B98		1174.2227.00		B	O
380	1	S		MZ BW2010 1E 1/2 T350 ABDECKUNG OBEN BW2010 1E 1/2 T350 COVER TOP entfällt in Kombination mit SGS-B98 / not applicable in combination with SGS-B98		1174.0082.00		M	W
450	2	S		MZ BW2010 1E T350 SEITENTEIL LINKS BW2010 1U D350 SIDE PANEL LEFT entfällt in Kombination mit SGS-B98 / not applicable in combination with SGS-B98		1174.1172.00		M	P
480	2	S		KN BW2010 1E RUECKWANDFUSS KOMPL BW2010 1HU REAR FOOT COMPL entfällt in Kombination mit SGS-B98 / not applicable in combination with SGS-B98	Z	1174.0024.00		B	T
720	2	S		MF BW2010 HALTER-FUSS BW2010 HOLDER-BASE entfällt in Kombination mit SGS-B98 / not applicable in combination with SGS-B98		1174.0376.00		M	B
730	2	S		VS 7985/ISR-M4X10-A4-PA 7985/ISR-M4X10-A4-PA entfällt in Kombination mit SGS-B98 / not applicable in combination with SGS-B98		1148.2669.00		B	O

 ROHDE & SCHWARZ	Benennung/Designation SGS100A SGMA RF SOURCE BASE UNIT SGS100A SGMA RF SOURCE BASE UNIT			Sprach./Lang de en	Ä.I. / C.I 12.00	Blatt/Sheet 2 of 2
	SGS100A	Datum/ Date	2012-04-16	Abt. / Dept.	1GPK	Name / Name
Dokument Nr. / Document No. 1416.0505.01 ST						

Für diese Unterlage behalten wir uns alle Rechte vor.
 Ausgedruckte Dokumente unterliegen nicht dem Änderungsdienst.
 For this document all rights are reserved.
 Printed documents are not subject to revision

Pos.-Nr. <i>ItemNo</i>	Menge <i>Quantity</i>	ME <i>Unit</i>	EI.Kennz <i>Ref.Des.</i>	Benennung / Bezeichnung <i>Designation</i>	Z	Sachnummer <i>Stock No.</i>	Ersatzteil <i>Subst.part</i>	BA	VH
				ACHTUNG EGB/ATTENTION ESD *VARIANTENERKLAERUNG *EXPLANATION OF MODELS VAR02=GRUNDVARIANTE MOD02=BASIC MODEL					
1810	1	S	A600	ED OCXO BOARD OCXO BOARD	Z	1416.2508.02	X	M	
1830	2	S		VS HVC/ISR-M2.5X12-A2 COMBINATION SCREWS		1096.5205.00		B	B

 ROHDE & SCHWARZ	Benennung/Designation SGS-B1 REFERENZOSZILLATOR SGS-B1 REFERENCE OSCILLATOR			Sprach./Lang de en	Ä.I. / C.I 02.00	Blatt/Sheet 1 of 1
	Datum/ Date	2011-03-02	Abt. / Dept.	1GPK	Name / Name	HI
SGS-B1						

Für diese Unterlage behalten wir uns alle Rechte vor.
 Ausgedruckte Dokumente unterliegen nicht dem Änderungsdienst.
 For this document all rights are reserved.
 Printed documents are not subject to revision

Pos.-Nr. ItemNo	Menge Quantity	ME Unit	El.Kennz Ref.Des.	Benennung / Bezeichnung Designation	Z	Sachnummer Stock No.	Ersatzteil Subst.part	BA	VH
				ACHTUNG EGB/ATTENTION ESD *VARIANTENERKLAERUNG *EXPLANATION OF MODELS VAR02=GRUNDVARIANTE MOD02=BASIC MODEL					
1610	1	S	A500	ED ASATT 13GHZ ASATT 13GHZ	Z	1412.5360.02	X	M	
1630	4	S		VS 965/ISR-M2.5X25-A4-PA 965/ISR-M2.5X25-A4-PA		1416.1547.00		B	O
1650	1	S	W206	DY FLACHBANDKABEL 26-POLIG R=1,27 RIBBON CABLE 26-POLE	Z	1416.1524.00	X	M	
1680	1	S	W110A	DW HF-KABEL W110A (RFBOARD ZU EICHLTG) RF CABLE W110A (RFBOARD TO ATT)	Z	1416.1501.00	X	M	
1690	1	S	W100A	DW HF-KABEL W100A (EICHLTG ZU HFAUSG) RF CABLE W110A (ATT TO RFOUT)	Z	1416.1499.00	X	M	

 ROHDE & SCHWARZ	Benennung/Designation SGS-B26 ELECTRONIC STEP ATTENUATOR SGS-B26 ELECTRONIC STEP ATTENUATOR			Sprach./Lang de en	Ä.I. / C.I 02.00	Blatt/Sheet 1 of 1
	Datum/ Date	2010-10-13	Abt. / Dept.	1GPK	Name / Name	HI

Für diese Unterlage behalten wir uns alle Rechte vor.
 Ausgedruckte Dokumente unterliegen nicht dem Änderungsdienst.
 For this document all rights are reserved.
 Printed documents are not subject to revision

Pos.-Nr. ItemNo	Menge Quantity	ME Unit	El.Kennz Ref.Des.	Benennung / Bezeichnung Designation	Z	Sachnummer Stock No.	Ersatzteil Subst.part	BA	VH
				ACHTUNG EGB/ATTENTION ESD *VARIANTENERKLAERUNG *EXPLANATION OF MODELS VAR02=GRUNDVARIANTE MOD02=BASIC MODEL					
311	1	S		OS GERAETESCHILD SGMA 6 GHZ CW LABEL		1416.2320.00		B	B
1010	1	S	A200	ED RF MAINBOARD RF MAINBOARD	Z	1416.1001.03	X	M	V
1040	3	S		VS HVC/ISR-M2.5X12-A2 COMBINATION SCREWS		1096.5205.00		B	B
1050	2	S		VS 6900/ISR-M2.5X6-A2 COMBINATION SCREWS		1148.3059.00		B	T
1060	1	S		VS 6900/ISR-M2.5X8-A2 COMBINATION SCREWS		0041.1653.00		B	T
1070	1	S		MZ HALTEWINKEL2 F. HF-AUSG MOUNTING BRACKET	Z	1416.0940.00		M	W
1080	2	S		VS 6900/ISR-M2.5X6-A2 COMBINATION SCREWS		1148.3059.00		B	T
1100	1	S	W100	DW HF-KABEL W100 (RF-BOARD ZU RUECKW.) RF CABLE W100 (RF BOARD TO REAR) entfällt in Kombination mit SGS-B26 / not applicable in combination with SGS-B26	Z	1416.0928.00	X	M	W
1120	1	S		MB ABSTANDSHUELSE 14MM LANG D5/2,7 DISTANCE SLEEVE 14MM LONG entfällt in Kombination mit SGS-B26 / not applicable in combination with SGS-B26		1416.1099.00		M	O
1130	1	S		DZ KABELBI.L100 B2.4 CABLETIE entfällt in Kombination mit SGS-B26 / not applicable in combination with SGS-B26		0209.4852.00		B	O
1140	1	S		VS 6900/ISR-M2.5X25-A2 COMBINATION SCREWS entfällt in Kombination mit SGS-B26 / not applicable in combination with SGS-B26		3584.5502.00		B	O

 ROHDE & SCHWARZ	Benennung/Designation SGS-B106 1MHZ TO 6GHZ, CW SGS-B106 1MHZ TO 6GHZ, CW			Sprach./Lang de en	Ä.I. / C.I 06.00	Blatt/Sheet 1 of 1	
	SGS-B106	Datum/ Date	2012-04-16	Abt. / Dept.	1GPK	Name / Name	HI
						Dokument Nr. / Document No. 1416.2308.01 ST	

Für diese Unterlage behalten wir uns alle Rechte vor.
 Ausgedruckte Dokumente unterliegen nicht dem Änderungsdienst.
 For this document all rights are reserved.
 Printed documents are not subject to revision

Pos.-Nr. ItemNo	Menge Quantity	ME Unit	El.Kennz Ref.Des.	Benennung / Bezeichnung Designation	Z	Sachnummer Stock No.	Ersatzteil Subst.part	BA	VH
				ACHTUNG EGB/ATTENTION ESD *VARIANTENERKLAERUNG *EXPLANATION OF MODELS VAR02=GRUNDVARIANTE MOD02=BASIC MODEL					
312	1	S		OS GERAETESCHILD SGMA 6 GHZ IQ LABEL		1416.2372.00		B	B
1020	1	S	A200	ED RF MAINBOARD RF MAINBOARD	Z	1416.1001.02	X	M	P
1040	3	S		VS HVC/ISR-M2.5X12-A2 COMBINATION SCREWS		1096.5205.00		B	B
1050	2	S		VS 6900/ISR-M2.5X6-A2 COMBINATION SCREWS		1148.3059.00		B	T
1060	1	S		VS 6900/ISR-M2.5X8-A2 COMBINATION SCREWS		0041.1653.00		B	T
1070	1	S		MZ HALTEWINKEL2 F. HF-AUSG MOUNTING BRACKET	Z	1416.0940.00		M	W
1080	2	S		VS 6900/ISR-M2.5X6-A2 COMBINATION SCREWS		1148.3059.00		B	T
1100	1	S	W100	DW HF-KABEL W100 (RF-BOARD ZU RUECKW.) RF CABLE W100 (RF BOARD TO REAR) entfällt in Kombination mit SGS-B26 / not applicable in combination with SGS-B26	Z	1416.0928.00	X	M	W
1120	1	S		MB ABSTANDSHUELSE 14MM LANG D5/2,7 DISTANCE SLEEVE 14MM LONG entfällt in Kombination mit SGS-B26 / not applicable in combination with SGS-B26		1416.1099.00		M	O
1130	1	S		DZ KABELBI.L100 B2.4 CABLETIE entfällt in Kombination mit SGS-B26 / not applicable in combination with SGS-B26		0209.4852.00		B	O
1140	1	S		VS 6900/ISR-M2.5X25-A2 COMBINATION SCREWS entfällt in Kombination mit SGS-B26 / not applicable in combination with SGS-B26		3584.5502.00		B	O

 ROHDE & SCHWARZ	Benennung/Designation SGS-B106V 1MHZ TO 6GHZ, IQ SGS-B106V 1MHZ TO 6GHZ, IQ			Sprach./Lang de en	Ä.I. / C.I 06.00	Blatt/Sheet 1 of 1
	Datum/ Date	2012-04-16	Abt. / Dept.	1GPK	Name / Name	HI
SGS-B106V						

Für diese Unterlage behalten wir uns alle Rechte vor.
 Ausgedruckte Dokumente unterliegen nicht dem Änderungsdienst.
 For this document all rights are reserved.
 Printed documents are not subject to revision

Pos.-Nr. ItemNo	Menge Quantity	ME Unit	El.Kennz Ref.Des.	Benennung / Bezeichnung Designation	Z	Sachnummer Stock No.	Ersatzteil Subst.part	BA	VH
				ACHTUNG EGB/ATTENTION ESD *VARIANTENERKLAERUNG *EXPLANATION OF MODELS VAR02=GRUNDVARIANTE MOD02=BASIC MODEL					
313	1	S		OS GERAETESCHILD SGMA 12.75 GHZ CW LABEL		1416.1560.00		B	B
1310	1	S	A400	EE DOUBLER BOARD DOUBLER BOARD	Z	1416.1601.02	X	M	P
1330	3	S		VS 965/ISR-M2.5X25-A4-PA 965/ISR-M2.5X25-A4-PA		1416.1547.00		B	O
1380	1	S	W207	DW HF-KABEL W207 RF CABLE W207	Z	1416.1724.00	X	M	P
1390	1	S	W208	DW HF-KABEL W208 RF CABLE W208	Z	1416.1730.00	X	M	O
1400	2	S	W209 W210	DW HF-KABEL W209 + 210 RF CABLE W209 + 210	Z	1416.1747.00	X	M	W
1650	1	S	W211	DY FLACHBANDKABEL 26-POLIG R=1,27 RIBBON CABLE 26-POLE	Z	1416.1524.00	X	M	P

 ROHDE & SCHWARZ	Benennung/Designation SGS-B112 FREQ EXT TO 12.75GHZ, CW SGS-B112 FREQ EXT TO 12.75GHZ, CW			Sprach./Lang de en	Ä.I. / C.I 04.00	Blatt/Sheet 1 of 1	
	SGS-B112	Datum/ Date	2012-04-16	Abt. / Dept.	1GPK	Name / Name	HI
						Dokument Nr. / Document No. 1416.1553.01 ST	

Für diese Unterlage behalten wir uns alle Rechte vor.
 Ausgedruckte Dokumente unterliegen nicht dem Änderungsdienst.
 For this document all rights are reserved.
 Printed documents are not subject to revision

Pos.-Nr. <i>ItemNo</i>	Menge <i>Quantity</i>	ME <i>Unit</i>	El.Kennz <i>Ref.Des.</i>	Benennung / Bezeichnung <i>Designation</i>	Z	Sachnummer <i>Stock No.</i>	Ersatzteil <i>Subst.part</i>	BA	VH
				ACHTUNG EGB/ATTENTION ESD VARIANTENERKLAERUNG EXPLANATION OF MODELS VAR02 GRUNDVARIANTE MOD02 BASIC MODEL					
314	1	S		OS GERAETESCHILD SGMA 12.75 GHZ IQ LABEL		1416.1582.00		B	B
1320	1	S	A400	EE DOUBLER BOARD DOUBLER BOARD	Z	1416.1601.03	X	M	O
1330	3	S		VS 965/ISR-M2.5X25-A4-PA 965/ISR-M2.5X25-A4-PA		1416.1547.00		B	O
1380	1	S	W207	DW HF-KABEL W207 RF CABLE W207	Z	1416.1724.00	X	M	P
1390	1	S	W208	DW HF-KABEL W208 RF CABLE W208	Z	1416.1730.00	X	M	O
1400	2	S	W209 W210	DW HF-KABEL W209 + 210 RF CABLE W209 + 210	Z	1416.1747.00	X	M	W
1650	1	S	W211	D FLACHBANDKABEL 26-POLIG R 1,27 RIBBON CABLE 26-POLE	Z	1416.1524.00	X	M	P

 ROHDE & SCHWARZ	Benennung/Designation SGS-B112V FREQ EXT TO 12.75GHZ, IQ SGS-B112V FREQ EXT TO 12.75GHZ, IQ			Sprach./Lang de en	.I. / C.I 04.00	Blatt/Sheet 1 of 1	
	SGS-B112V	Datum/ Date	2012-04-17	Abt./ Dept.	1GPK	Name / Name	HI
Dokument Nr. / Document No.						1416.1576.01 ST	

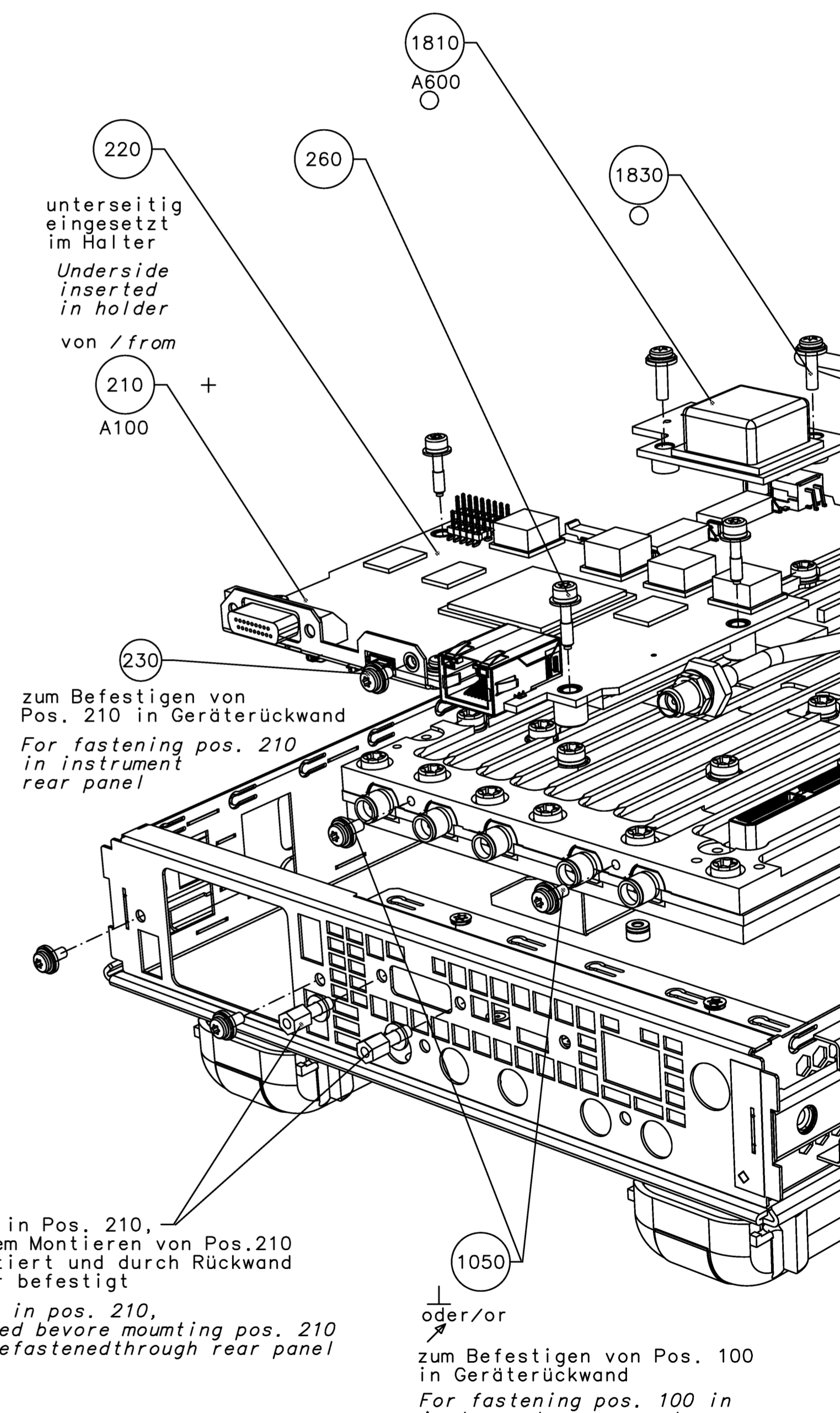
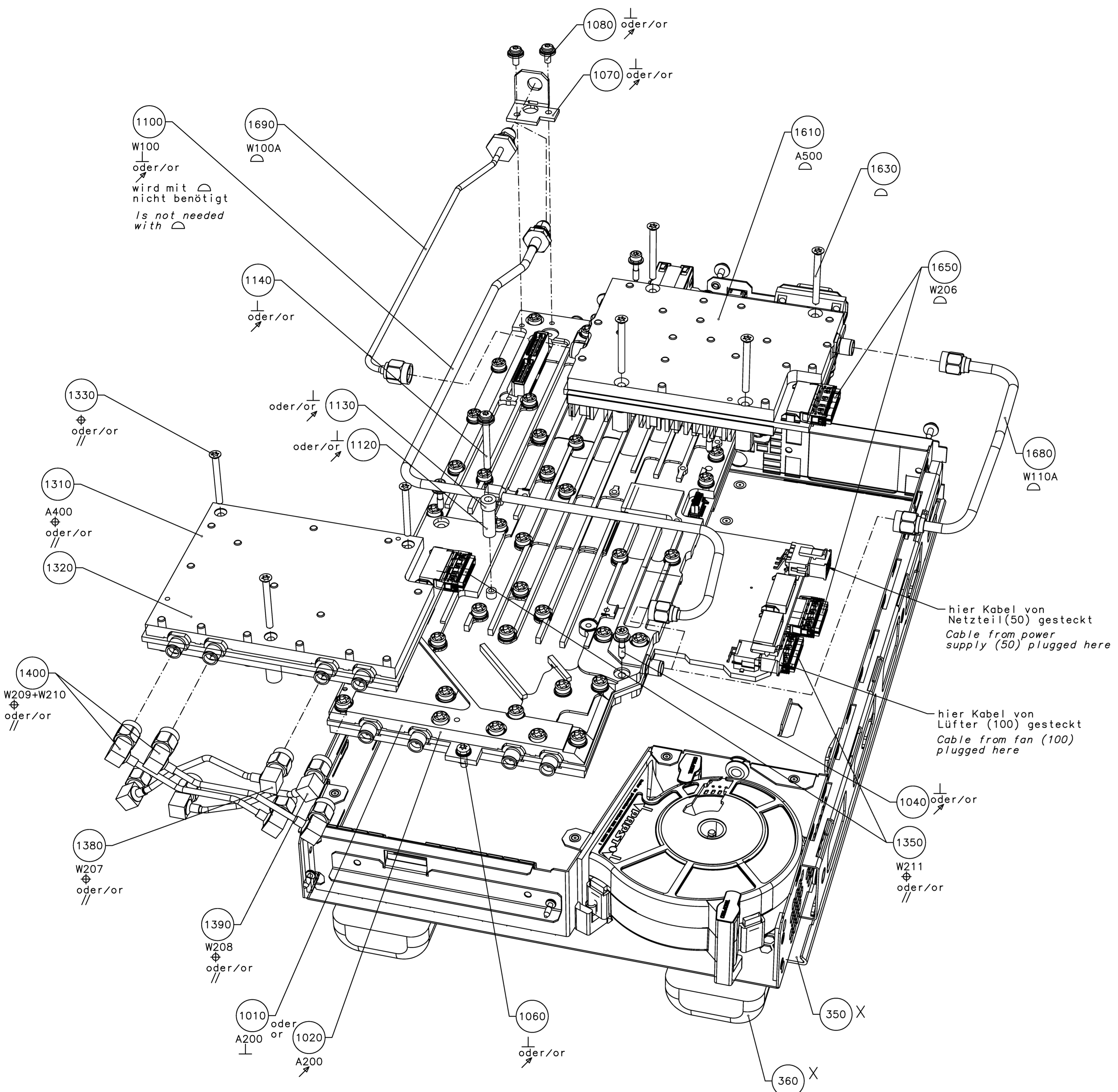

Für dieses Dokument behalten wir uns alle Rechte vor
For this document all rights are reserved

Projektionsmethode
Projection Method

X = entfällt mit SGS-B98
not used with SGS-B98

ohne Pos. 280 und Pos. 380 dargestellt
without pos. 280 and pos. 380

Für diese Montagezeichnung sind folgende Stücklisten relevant:
The following parts lists are relevant for this assembly drawing

○	1416.0505.01	SGS100A
○	1416.2408.01	SGS-B1
○	1416.1353.01	SGS-B26
○	1416.2108.01	SGS-B98
○	1416.2308.01	SGS-B106
○	1416.2350.01	SGS-B106V
○	1416.1553.01	SGS-B112
○	1416.1576.01	SGS-B112V

Variantenerklärung: VAR02 = Grundauführung
Explanation of Models: MOD02 = Basic model

Modell Type	ISO 9001 Zertifizierung Certification	ISO 2768-m Toleranzen Tolerances	Netzteil Power supply	Sprache / Lang. Language	Blatt / von Page / of
ROHDE & SCHWARZ				de en	03.00 1
SGS100A					
	Datum Date	2010-12-07	Druck Print	16PK	Hx
					1416.0505.01 D

ACHTUNG EGB!
CAUTION ESD!

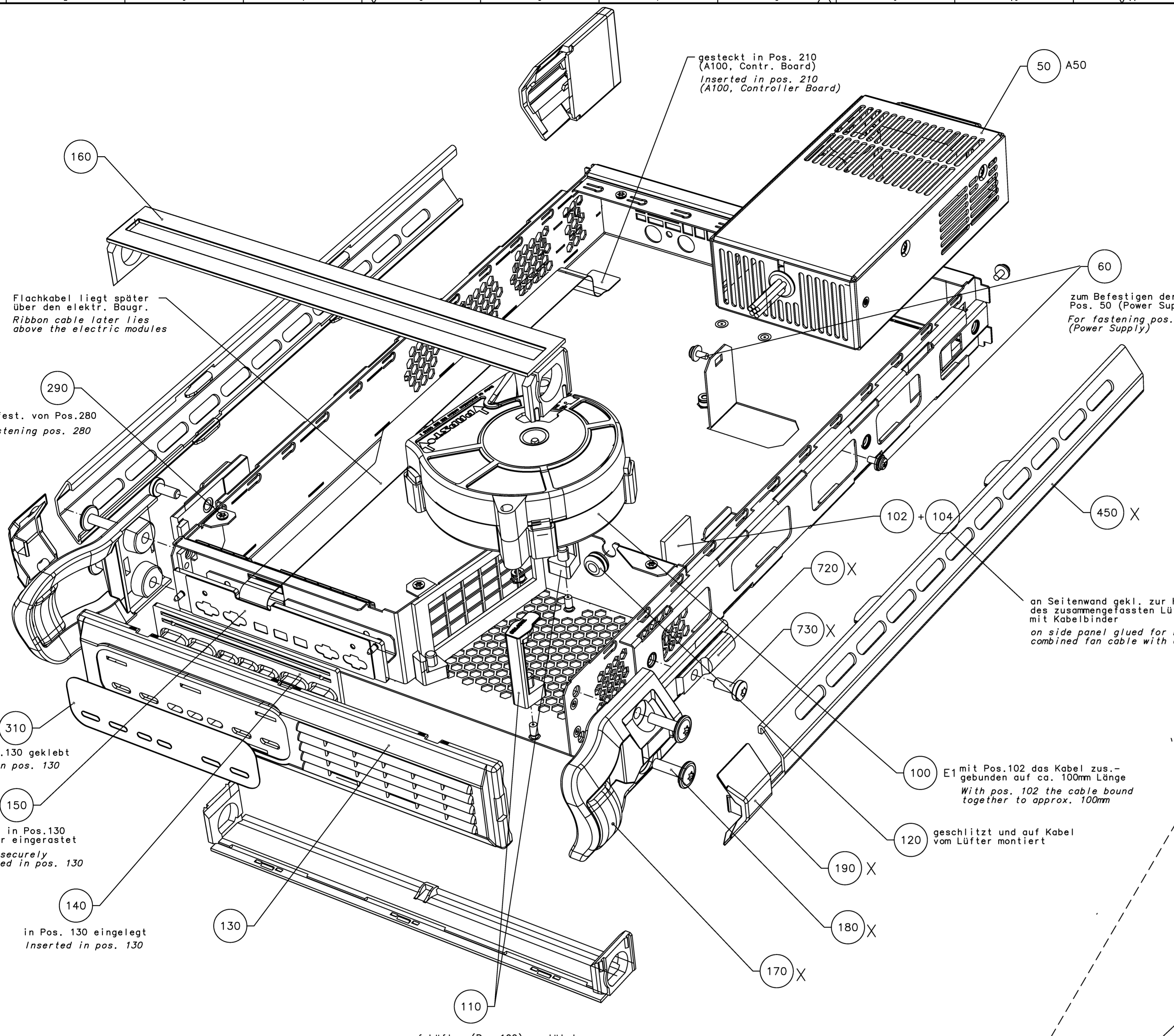

Flachkabel liegt später über den elektr. Baugr.
Ribbon cable later lies above the electric modules

zur Befest. von Pos.280
For fastening pos. 280

auf Pos.130 geklebt
Glued on pos. 130

A300, in Pos.130 sicher eingerastet
A300 securely engaged in pos. 130

in Pos. 130 eingelegt
Inserted in pos. 130

auf Lüfter (Pos.100) gestülpt und auf Gewindebolzen gedrückt
Put over fan (pos. 100) and thus pressed onto threaded stud

gesteckt in Pos. 210 (A100, Contr. Board)
Inserted in pos. 210 (A100, Controller Board)

zum Befestigen der Pos. 50 (Power Supply)
For fastening pos. 50 (Power Supply)

an Seitenwand gekl. zur Halterung des zusammengefassten Lüfterkabels mit Kabelbinder
on side panel glued for holding combined fan cable with cable tie

E1 mit Pos.102 das Kabel zus.-gebunden auf ca. 100mm Länge
With pos. 102 the cable bound together to approx. 100mm

geschlitzt und auf Kabel vom Lüfter montiert

geklebt zwischen die 4 Fangwarzen
Glued in the area marked with the captive pads

1. Teil von SAP-Schild geklebt, so daß es nicht vom Rückwandfuß verdeckt wird
First part of label glued so that label is not covered by the rear panel foot

2. Teil von SAP-Schild geklebt
Second part of SAP label glued

zum Befestigen der Pos.50
For fastening pos. 50

X = entfällt mit SGS-B98
not used with SGS-B98

Für diese Montagezeichnung ist die Stückliste 1416.0505.01 relevant.
The following parts list are relevant for this assembly drawing: 1416.0505.01 ST

ohne Pos. 280 und Pos.380 dargestellt
Shown without pos. 280 and pos. 380

Für dieses Dokument behalten wir uns alle Rechte vor
For this document all rights are reserved

Projektionsmethode
Projection Method

Hersteller Rohde & Schwarz	Teilnummer SGS100A	ISO 2768-m	Netzteil 16PK	Druck / Long. / C.F. de en	Blatt / 28 03.00	2
	SGS100A SGMA RF SOURCE BASE UNIT				1416.0505.01	D



ROHDE & SCHWARZ

Block Circuit Diagram

SGS100A

Front Panel

Rear Panel

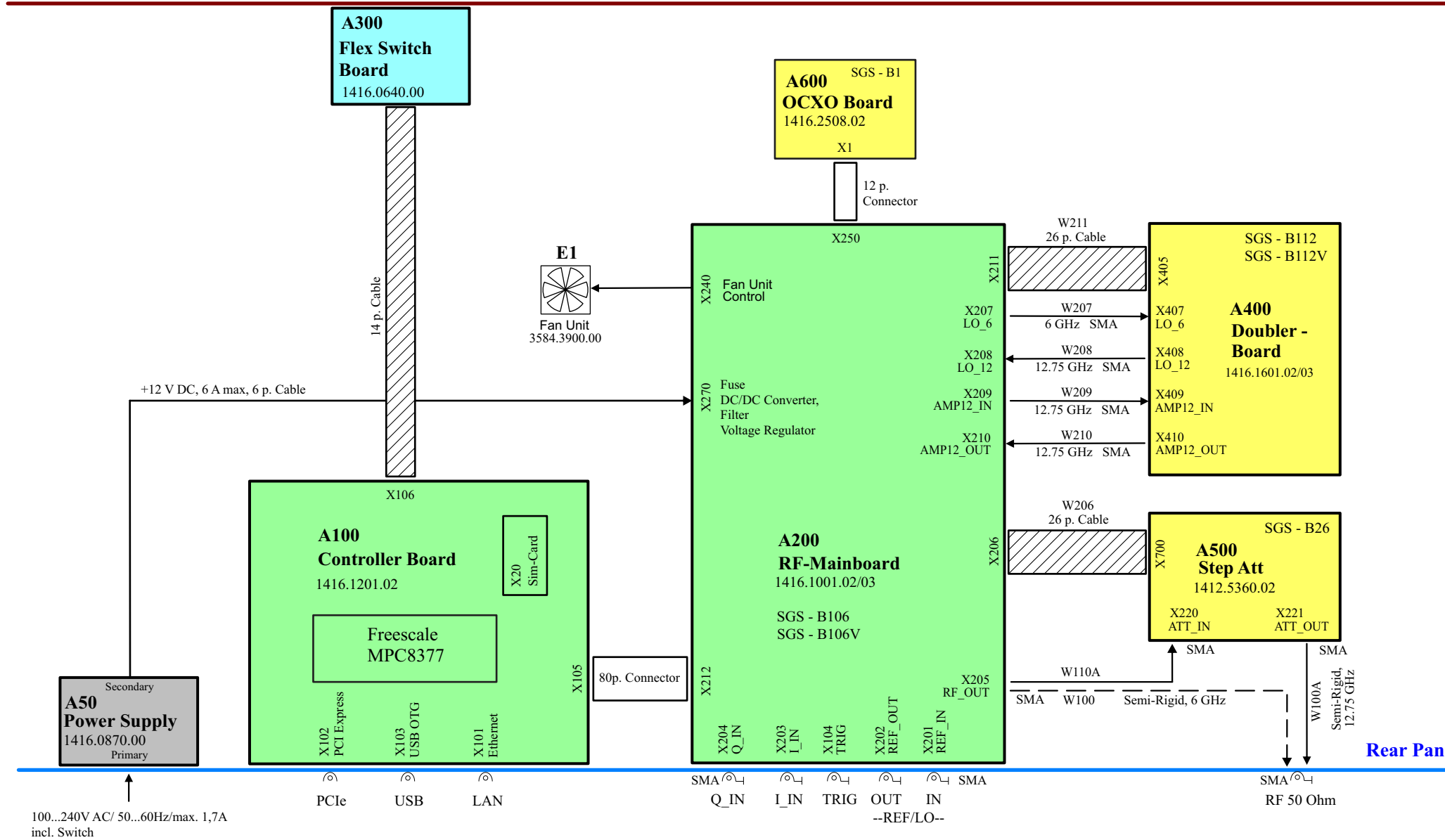

Für diese Unterlage behalten wir uns alle Rechte vor.

(D)

ISO-Projektion
Methode E



ROHDE&SCHWARZ		Benennung: Designation: SGS100A SGMA RF SOURCE BASE UNIT		Sprache: / Lang.: de	Aei: / C.I.: 04.00	Blatt: / Sh.: 1 -	
Type: Type:	SGS100A	Datum: Date:	07.04.2011	Abteilung: Dept.:	1GPK	Name: Name:	Raab
used in:	1416.0505.01	Zeichn. Nr.: / Drawing Nr.:				1416.0505.01 FS	

Für diese Unterlage behalten wir uns alle Rechte vor.

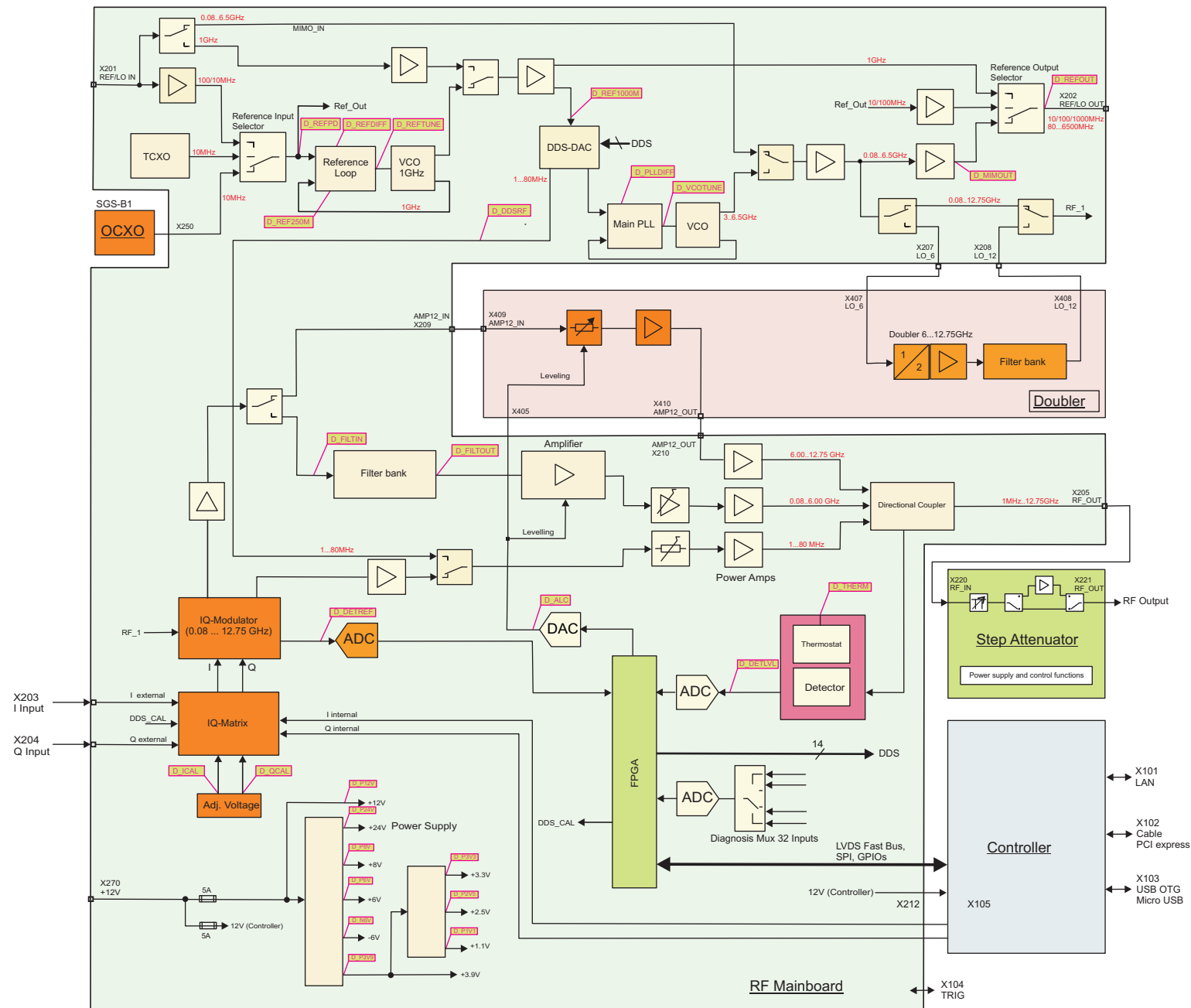

Matstabs: / Scale: / Toleranz: / Tol:		Rauht.: / Roughn.: / Kanten: / Edges:		Werkstoff: / Material:		Werknormen: / Company Standards:	
ROHDE&SCHWARZ				Benennung: / Designation: RFMB u GesamtBlock SIGMA 12 GHz		Sprache: / Lang.: 06.00	Blatt: / Sh.: 1-
Typ: / Type: SIGMA		Datum: / Date: 2011-06-17	Abteilung: / Dept.: 1GP4	Name: / Name: J. Kuptz		Zeichn. Nr.: / Drawing Nr.: 1416.1001.01 FS	

ISO-Projektion
Methode E

Index

Adjustments	
External	49
Internal	49
Internal Reference Frequency	49
Dismounting the Case	87
Frequency Error	81
Functional Description	
Controller Board	52
Doubler Board	56
Power Supply Module	52
Reference Oscillator	58
RF Mainboard	53
Step Attenuator	57
Installing	
Controller	100
Doubler Board	113
Electronic Step Attenuator	116
EMC Panel	89
Flex Switch Board	106
Power Supply	92
Push-Button Board	106
RF Mainboard	95
Instrument Faults	65
Internal Self Test	50
Keyboard and LED Test	62
Measuring Equipment and Accessories	60
Module Replacement	85
Modules overview	86
Motherboard	52
Mounting the Case	88
Overview of the Modules	86
Performance Test	8
Power Cables	120
Power Supply Module	52
Removing	
Controller	98
EMC Panel	89
Flex Switch Board	104
Front Unit	102
OCXO Board	110
Power Supply	90
Push-Button Board	104
RF Mainboard	93
Repair	51
Replacing	
Controller Board	98
Doubler Board	111
EMC Panel	89
Fan	108
Flex Switch Board	104
Front Unit	102
OCXO Board	110
Power Supply	90
RF Mainboard	93
SIM Card	102
Spare Parts	120
Switch-On Problems	60, 61, 62
Test Assemblies	
I/Q Modulation	12
Output Impedance (VSWR)	11
Setting Time	11
SSB Phase Noise and Jitter	10
Test Equipment	8
Test Frequencies	13
Test Levels	13
Test Procedures	
Frequency	16
I/Q modulation	38
Level Data	33
PCI Express Interface	45
Phase Coherence Levels	45
Reference Frequency	14
Spectral Purity	20
Troubleshooting	59
Active Step Attenuator	81
Doubler Board Option	83
Internal Adjustments	64
Internal Selftest	63
Reference Oscillator Option	78
RF Mainboard	73
Switch-On Problems	61, 62